

Phrase Lab MC-09

Owner's Manual

Before using this unit, carefully read the sections entitled: "USING THE UNIT SAFELY" and "IMPORTANT NOTES" (p. 2, 3; p. 4, 5). These sections provide important information concerning the proper operation of the unit. Additionally, in order to feel assured that you have gained a good grasp of every feature provided by your new unit, Owner's manual should be read in its entirety. The manual should be saved and kept on hand as a convenient reference.

Listening to the demo performance

The MC-09 contains a demo performance. This demo also contains the steps of the procedure by which the demo performance was created, along with various settings. By playing back the demo performance you can learn about the features of the MC-09.

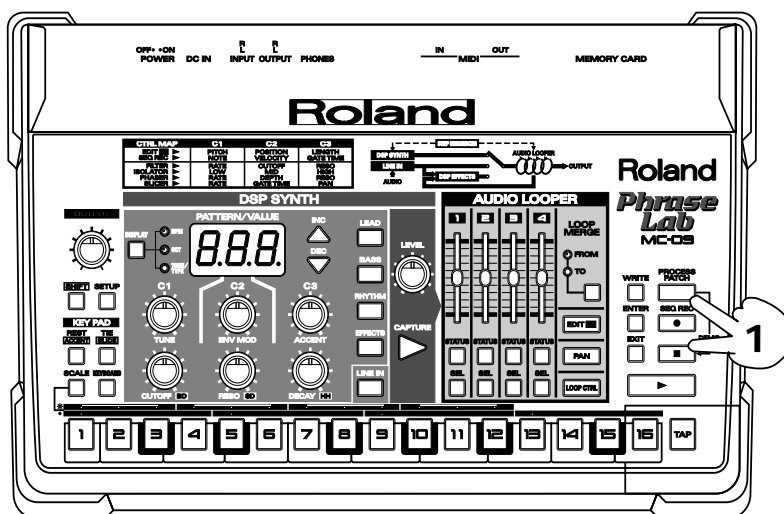

1. Hold down the [PROCESS PATCH] button and press the [■] (STOP) button.

The MC-09 first takes you through all the steps that were taken in creating the demo performance, then the demo performance loop begins automatically.





Thanks to its **Process Patch** feature, the MC-09 is able to keep a record of the procedures you follow, and the settings you make (p. 39).

* SmartMedia is a trademark of Toshiba Corp.







USING THE UNIT SAFELY

INSTRUCTIONS FOR THE PREVENTION OF FIRE, ELECTRIC SHOCK, OR INJURY TO PERSONS

About WARNING and CAUTION Notices









 WARNING	Used for instructions intended to alert the user to the risk of death or severe injury should the unit be used improperly.
 CAUTION	Used for instructions intended to alert the user to the risk of injury or material damage should the unit be used improperly. * Material damage refers to damage or other adverse effects caused with respect to the home and all its furnishings, as well to domestic animals or pets.







About the Symbols

	The  symbol alerts the user to important instructions or warnings. The specific meaning of the symbol is determined by the design contained within the triangle. In the case of the symbol at left, it is used for general cautions, warnings, or alerts to danger.
	The  symbol alerts the user to items that must never be carried out (are forbidden). The specific thing that must not be done is indicated by the design contained within the circle. In the case of the symbol at left, it means that the unit must never be disassembled.
	The  symbol alerts the user to things that must be carried out. The specific thing that must be done is indicated by the design contained within the circle. In the case of the symbol at left, it means that the power-cord plug must be unplugged from the outlet.

ALWAYS OBSERVE THE FOLLOWING

WARNING

- Before using this unit, make sure to read the instructions below, and the Owner's Manual. 
- Do not open (or modify in any way) the unit or its AC adaptor. 
- Do not attempt to repair the unit, or replace parts within it (except when this manual provides specific instructions directing you to do so). Refer all servicing to your retailer, the nearest Roland Service Center, or an authorized Roland distributor, as listed on the "Information" page. 
- Never use or store the unit in places that are:
 - Subject to temperature extremes (e.g., direct sunlight in an enclosed vehicle, near a heating duct, on top of heat-generating equipment); or are 
 - Damp (e.g., baths, washrooms, on wet floors); or are 
 - Humid; or are
 - Exposed to rain; or are
 - Dusty; or are
 - Subject to high levels of vibration.
- Make sure you always have the unit placed so it is level and sure to remain stable. Never place it on stands that could wobble, or on inclined surfaces. 
- Be sure to use only the AC adaptor supplied with the unit. Also, make sure the line voltage at the installation matches the input voltage specified on the AC adaptor's body. Other AC adaptors may use a different polarity, or be designed for a different voltage, so their use could result in damage, malfunction, or electric shock. 

- Do not excessively twist or bend the power cord, nor place heavy objects on it. Doing so can damage the cord, producing severed elements and short circuits. Damaged cords are fire and shock hazards! 
- This unit, either alone or in combination with an amplifier and headphones or speakers, may be capable of producing sound levels that could cause permanent hearing loss. Do not operate for a long period of time at a high volume level, or at a level that is uncomfortable. If you experience any hearing loss or ringing in the ears, you should immediately stop using the unit, and consult an audiologist. 
- Do not allow any objects (e.g., flammable material, coins, pins); or liquids of any kind (water, soft drinks, etc.) to penetrate the unit. 

- Immediately turn the power off, remove the AC adaptor from the outlet, and request servicing by your retailer, the nearest Roland Service Center, or an authorized Roland distributor, as listed on the "Information" page when:
 - The AC adaptor or the power-supply cord has been damaged; or
 - Objects have fallen into, or liquid has been spilled onto the unit; or
 - The unit has been exposed to rain (or otherwise has become wet); or
 - The unit does not appear to operate normally or exhibits a marked change in performance.
- In households with small children, an adult should provide supervision until the child is capable of following all the rules essential for the safe operation of the unit. 

- Protect the unit from strong impact. (Do not drop it!)



- Do not force the unit's power-supply cord to share an outlet with an unreasonable number of other devices. Be especially careful when using extension cords—the total power used by all devices you have connected to the extension cord's outlet must never exceed the power rating (watts/amperes) for the extension cord. Excessive loads can cause the insulation on the cord to heat up and eventually melt through.



- Before using the unit in a foreign country, consult with your retailer, the nearest Roland Service Center, or an authorized Roland distributor, as listed on the "Information" page.



CAUTION

- The unit and the AC adaptor should be located so their location or position does not interfere with their proper ventilation.



- Always grasp only the plug or the body of the AC adaptor when plugging into, or unplugging from, an outlet or this unit.



- Whenever the unit is to remain unused for an extended period of time, disconnect the AC adaptor.



- Try to prevent cords and cables from becoming entangled. Also, all cords and cables should be placed so they are out of the reach of children.



- Never climb on top of, nor place heavy objects on the unit.



- Never handle the AC adaptor body, or its plugs, with wet hands when plugging into, or unplugging from, an outlet or this unit.



- Before moving the unit, disconnect the AC adaptor and all cords coming from external devices.



- Before cleaning the unit, turn off the power and unplug the AC adaptor from the outlet (p.12).



- Whenever you suspect the possibility of lightning in your area, disconnect the AC adaptor from the outlet.



- Should you remove screws, make sure to put them in a safe place out of children's reach, so there is no chance of them being swallowed accidentally.



IMPORTANT NOTES

In addition to the items listed under “USING THE UNIT SAFELY” on pages 2 – 3, please read and observe the following:

Power Supply

- Do not use this unit on the same power circuit with any device that will generate line noise (such as an electric motor or variable lighting system).
- The AC adaptor will begin to generate heat after long hours of consecutive use. This is normal, and is not a cause for concern.
- Before connecting this unit to other devices, turn off the power to all units. This will help prevent malfunctions and/or damage to speakers or other devices.

Placement

- Using the unit near power amplifiers (or other equipment containing large power transformers) may induce hum. To alleviate the problem, change the orientation of this unit; or move it farther away from the source of interference.
- This device may interfere with radio and television reception. Do not use this device in the vicinity of such receivers.
- Noise may be produced if wireless communications devices, such as cell phones, are operated in the vicinity of this unit. Such noise could occur when receiving or initiating a call, or while conversing. Should you experience such problems, you should relocate such wireless devices so they are at a greater distance from this unit, or switch them off.
- Do not expose the unit to direct sunlight, place it near devices that radiate heat, leave it inside an enclosed vehicle, or otherwise subject it to temperature extremes. Excessive heat can deform or discolor the unit.
- To avoid possible breakdown, do not use the unit in a wet area, such as an area exposed to rain or other moisture.

Maintenance

- For everyday cleaning wipe the unit with a soft, dry cloth or one that has been slightly dampened with water. To remove stubborn dirt, use a cloth impregnated with a mild, non-abrasive detergent. Afterwards, be sure to wipe the unit thoroughly with a soft, dry cloth.
- Never use benzine, thinners, alcohol or solvents of any kind, to avoid the possibility of discoloration and/or deformation.

Additional Precautions

- Please be aware that the contents of memory can be irretrievably lost as a result of a malfunction, or the improper operation of the unit. To protect yourself against the risk of losing important data, we recommend that you periodically save a backup copy of important data you have stored in the unit’s memory in another MIDI device (e.g., a sequencer).

- Unfortunately, it may be impossible to restore the contents of data that was stored in another MIDI device (e.g., a sequencer) once it has been lost. Roland Corporation assumes no liability concerning such loss of data.
- Use a reasonable amount of care when using the unit’s buttons, sliders, or other controls; and when using its jacks and connectors. Rough handling can lead to malfunctions.
- When connecting / disconnecting all cables, grasp the connector itself—never pull on the cable. This way you will avoid causing shorts, or damage to the cable’s internal elements.
- To avoid disturbing your neighbors, try to keep the unit’s volume at reasonable levels. You may prefer to use headphones, so you do not need to be concerned about those around you (especially when it is late at night).
- When you need to transport the unit, package it in the box (including padding) that it came in, if possible. Otherwise, you will need to use equivalent packaging materials.
- Use a cable from Roland to make the connection. If using some other make of connection cable, please note the following precautions.
 - Some connection cables contain resistors. Do not use cables that incorporate resistors for connecting to this unit. The use of such cables can cause the sound level to be extremely low, or impossible to hear. For information on cable specifications, contact the manufacturer of the cable.

Before Using Memory Cards

- Carefully insert the memory card all the way in—until it is firmly in place.

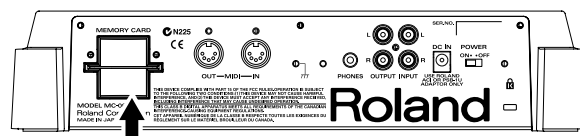

The surface without gold contacts must face upward.

- Never touch the terminals of the memory card. Also, avoid getting the terminals dirty.

Copyright

- Unauthorized recording, distribution, sale, lending, public performance, broadcasting, or the like, in whole or in part, of a work (musical composition, video, broadcast, public performance, or the like) whose copyright is held by a third party is prohibited by law.
- Do not use this unit for purposes that could infringe on a copyright held by a third party. We assume no responsibility whatsoever with regard to any infringements of third-party copyrights arising through your use of this unit.

Saving data

Saving patterns

After you've edited a pattern or recorded in the step sequencer, you must save your work in the MC-09's internal **user memory**, or on a **memory card** if you want to keep it. **If you turn off the power without saving your work, your settings and recorded material will be lost.**

- Saving a pattern (p. 30)
- Saving an effect pattern (p. 48)

Saving a loop (p. 59)

After you record (capture) a loop, you must save it to a **memory card** if you want to keep it. **If you turn off the power without doing this, your settings and recorded material will be lost.**

Saving a process patch (p. 39)

The MC-09 lets you save the sequence of steps you've used in creating a loop, together with the pattern settings that you used at that time. This is called a Process Patch.

When you play back a process patch that you've saved, the MC-09 will carry out the same process as when you created the loop, and the loop will be recreated. In other words, a process patch is somewhat like a keyboard macro on a personal computer.

About the display

The MC-09's display shows letters and numerals as follows.

	A	B	C	D	E	F	G	H	I	J	K	L	M	N
capital letter	A	b	C	d	E	F	G	H	I	J	K	L	M	N
small letter	a	c	e	g	h	i	j							
	O	P	Q	R	S	T	U	V	W	X	Y	Z		
capital letter	O	P	Q	R	S	T	U	V	W	X	Y	Z		
small letter	o				t	u	=							
	1	2	3	4	5	6	7	8	9	0	-1	#		
	1	2	3	4	5	6	7	8	9	0	-1	#		

Restoring the factory settings (Factory Reset)

By carrying out a Factory Reset, the following settings of the MC-09 are restored to their original factory-set condition.

- System settings
- All patterns you've saved (User Patterns)
- * *Once you execute a Factory Reset, all the settings you've saved will be lost, being replaced by the settings your unit originally had when it left the factory. If internal memory contains important data that you want to keep, you must save it on a memory card (p. 59), or to an external MIDI sequencer via bulk dump (p. 65).*

1. Press the [SETUP] button.
2. Press the [INC] or [DEC] button until the display indicates "Fct".
3. Press the [ENTER] button.

The display will show "Sur".

4. To execute the factory reset, press the [WRITE] button.

While the factory settings are being restored, "b5Y" will appear in the display. When the factory reset is finished, you're returned to where you were in step 2.

- * *If you decide not to restore the factory settings, press the [SETUP] button or the [EXIT] button.*
- * *Never turn off the power while b5Y appears in the display. Doing so will damage the system.*

5. Press the [SETUP] button to return to the previous display.

About the included CD

The CD contains loop samples. Since the disc is in CD-EXTRA format, you can either play back the samples on a CD player, or use your computer to handle the data as EXTRA TRACK computer data.

- Avoid touching or scratching the shiny underside (encoded surface) of the disc. Damaged or dirty CD discs may not be read properly. Keep your discs clean using a commercially available CD cleaner.
- Use of the CD supplied with this product for any purpose other than private, personal enjoyment without the permission of the copyright holder is prohibited by law. Additionally, this data must not be copied, nor used in a secondary copyrighted work without the permission of the copyright holder.

Contents

IMPORTANT NOTES	4
Saving data	5
About the display	5
Restoring the factory settings (Factory Reset)	5
About the included CD	5
Contents	6
Names of things and what they do	8
Main features and uses	11
Main features	11
Ways to use the MC-09	11
Making connections	12
Turning the power on/off	13
Using the MC-09 as a synthesizer	14
What is a pattern?	14
Playing	15
Modifying the sound	20
Creating a phrase (Recording)	23
Saving a pattern	30
Creating and playing a loop	31
What is a loop?	31
The process of creating a loop	32
Recording (capturing)	33
Playback	35
Changing the settings of part 1	37
Combining several parts into one (Loop Merge)	38
Erasing the contents of a part	39
Saving the steps by which you created a loop (Process Patch)	39
Applying an effect	41
Specifying the effect routing	41
Turning the effect on/off	42
Selecting an effect pattern	42
Using the knobs to adjust the effect settings	43
Changing the effect type	44
Creating consecutive changes in an effect (Effect Control)	45
Saving your effect settings	48
Changing the way in which a loop plays (Loop Control)	49
What is Loop Control?	49
Using loop control for realtime performance	51
Playing back a loop with Loop Control	53
Making loop control settings	54
Saving your loop control settings	56
About the tempo	57
Checking the standard tempo	57
Setting the tempo manually	57
Setting the tempo with the [TAP] button	57

Using a memory card58

- Memory cards usable with the MC-09 58
- Cautions when using a memory card..... 58
- Formatting a memory card 58
- Saving a loop to a memory card..... 59
- Loading a loop 59
- Deleting a saved loop from memory card 59
- Saving all settings of the MC-09 to a memory card..... 60
- Loading MC-09 settings..... 60
- Deleting saved MC-09 settings from a memory card..... 60

Connecting external MIDI devices.....61

- Setting the MIDI channel..... 61
- Using the MC-09 as the master..... 61
- Using the MC-09 as the slave..... 63
- Using the MC-09 with your computer 64
- Saving the MC-09 settings to an external sequencer (Bulk Dump)..... 65

How the MC-09 is organized66

What knobs do67

Parameter list68

Troubleshooting.....72

Error messages.....73

Specifications.....75

Sound List76

Index.....82

Operation map.....84

Blank Chart.....86

Names of things and what they do

Front Panel

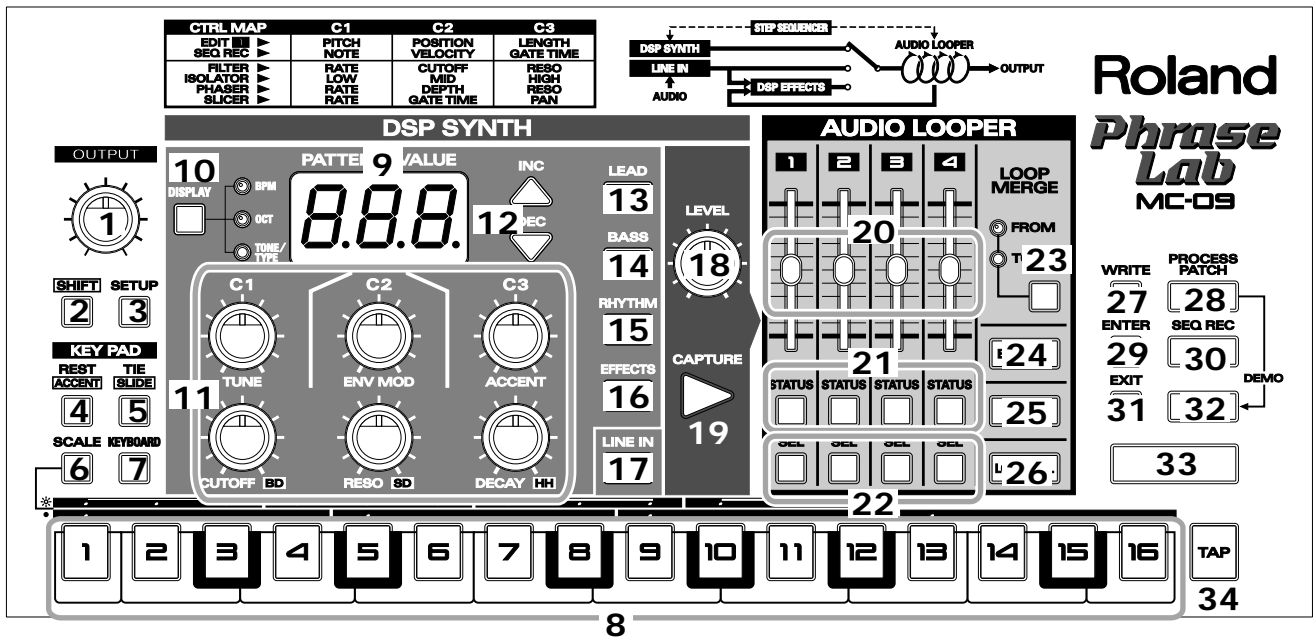

Common Section

1. [OUTPUT] Knob..... (p. 13)

This knob adjusts the overall volume.

2. [SHIFT] Button

This button is used in conjunction with other buttons.

3. [SETUP] Button

This button is used for making settings concerned with the tuning, MIDI, etc.

4. [REST] Button/[ACCENT] Button

[REST] Button (p. 26), (p. 27)

This button inputs a rest while recording.

[ACCENT] Button..... (p. 26), (p. 28)

When you hold down the [SHIFT] button and press this button while recording, an accent will be added to the step you are currently inputting.

5. [TIE] Button/[SLIDE] Button

[TIE] Button (p. 26), (p. 27)

This button inputs a tie while recording.

[SLIDE] Button (p. 26)

When you hold down the [SHIFT] button and press this button while recording, the Slide-on function will be turned on.

6. [SCALE] Button..... (p. 24)

This button selects the note value unit (step time) when recording.

16th notes: indicator dark

8th note triplets: indicator lit

7. [KEYBOARD] Button..... (p. 18)

Press this button so the indicator lights when you want to use the step [1]-[16] buttons as a keyboard (keyboard pads).

8. Step [1]-[16] Buttons/Keyboard Pads

Step [1]-[16] Buttons

Use these buttons to specify steps of the sequencer.

Keyboard Pads..... (p. 18)

The buttons can be used as a keyboard.

DSP Synthesizer Section

9. Display

Various information such as pattern numbers and parameter values will be shown in this display.

10. [DISPLAY] Display Button

This button switches the values that are shown in the display.

Each time you press the button the display will cycle as follows.

Indicator dark: Pattern number

BPM: Tempo (p. 57)

OCT: Octave Shift setting

TONE/TYPER: Sound (tone) used by the pattern, or the type of effect

11. C1 Knob, C2 Knob, C3 Knob, CUTOFF/BD Knob, RESO/SD Knob, DECAY/HH Knob

Use these knobs to adjust various parameters such as cutoff frequency, resonance, and drum volume.

* *The function of the knobs will depend on the operating mode. For details, refer to "What knobs do" (p. 67).*

12. [INC], [DEC] Buttons

Use these knobs to switch patterns or to set various values.

13. [LEAD] Button..... (p. 14)

Press this button so the indicator lights when you want to play melodies or solos using a pattern from the LEAD group.

14. [BASS] Button (p. 14)

Press this button so the indicator lights when you want to play bass using a pattern from the BASS group.

15. [RHYTHM] Button (p. 14)

Press this button so the indicator lights when you want to play drums or percussion using a pattern from the RHYTHM group.

16. [EFFECTS] Button (p. 41)

Press this button so the indicator lights when you want to apply effects to a loop or audio signal.

17. [LINE IN] Button (p. 19)

Press this button so the indicator lights when you want to input an audio signal.

MEMO

If you want to mix the audio signal with the pattern playback, press the [SHIFT] button at the same time (p. 19).

18. LEVEL Knob..... (p. 13)

This knob adjusts the volume of the audio signal or DSP synthesizer.

When you are capturing a loop, this knob adjusts the capture volume.

19. [CAPTURE] Button (p. 33)

This button records (captures) an audio signal.

Audio Looper Section

20. Part Volume Sliders (p. 35)

These sliders adjust the volume for each part of the audio looper.

21. [STATUS] Buttons (p. 36)

These buttons switch each part between muted and unmuted.

The indicators show the status of each track.

- Lit: play
- Blinking: don't play (mute)
- Dark: no sound is recorded

22. [SEL] Buttons

Use these buttons to select the part(s) to which you want to apply an effect or Loop Merge.

23. [LOOP MERGE] Button..... (p. 38)

This button lets you merge audio loops ("bounce recording").

24. [EDIT 1] Button (p. 37)

Use this button to edit the settings of part 1.

25. [PAN] Button (p. 36)

Use this button to set the pan (stereo position).

26. [LOOP CTRL] Button (p. 49)

Use this button to change the way in which the loop is played.

Common Section

27. [WRITE] Button

Use this button to save sounds, effects, or loop control settings.

28. [PROCESS PATCH] Button (p. 39)

Use this button to save or load a process patch (p. 39).

29. [ENTER] Button

This button finalizes the pattern you select or a parameter value you edit.

30. [●](SEQ REC) Button

Use this button to record, to make effect settings, or to cyclically modify a loop.

31. [EXIT] Button

Pressed to cancel settings and other various operations.

32. [■](STOP) Button

Press this button to stop playback for a pattern or loop.

33. [▶](PLAY) Button

Press this button to play back a pattern or loop.

34. [TAP] Button (p. 57)

You can set the tempo by pressing this button at the desired interval.

Rear Panel

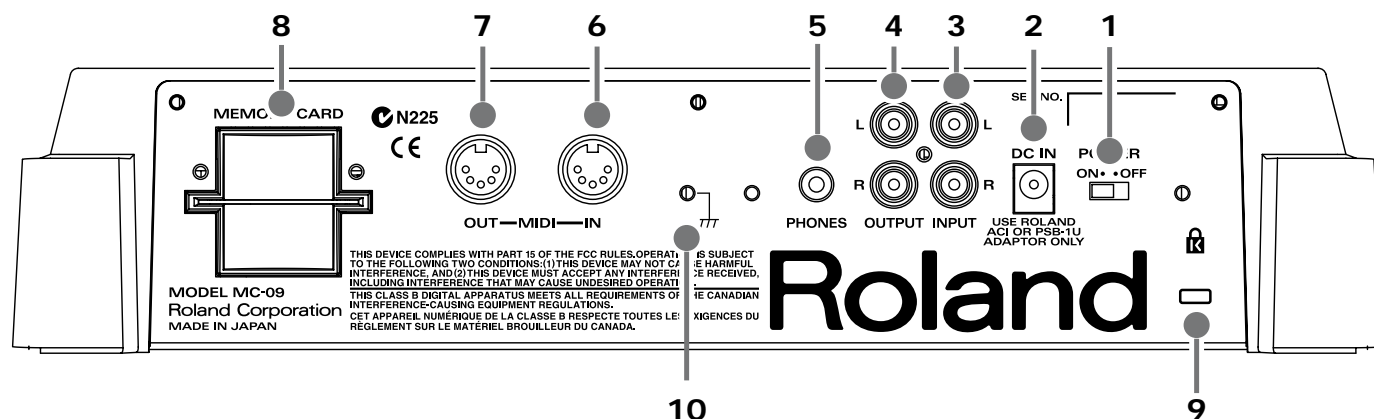

1. POWER Switch

This switch turns the power on/off.

2. DC IN Jack

Connect the included AC adaptor to this jack.

* Use only the AC adaptor that was included with the MC-09.

3. INPUT L, R Jacks

These jacks input audio signals. Connect your CD player, MD player, or synthesizer to these jacks.

4. OUTPUT L, R Jacks

These jacks output audio signals. Connect these jacks to your powered speaker system, mixer, or amp.

5. PHONES Jack

You can connect a pair of headphones to this jack.

6. MIDI IN Jack

This jack receives MIDI messages from an external MIDI device.

7. MIDI OUT Jack

This jack transmits MIDI messages to an external MIDI device.

8. MEMORY CARD Slot

You can insert a separately sold memory card into this slot.



The MC-09 provides a card protector to prevent theft of the memory card. To install the card protector, use the following procedure.

1. Use a screwdriver to remove both screws that are at either side of the memory card slot.
2. Insert the memory card into the memory card slot.
3. Use the screws to fasten the card protector as shown below.

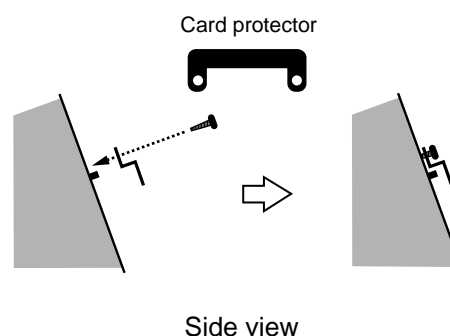

9. Security Slot

See the following;

<http://www.kensington.com/>

10. Ground terminal

In some cases, depending on the environment in which the unit is installed, the surface of the panel may sometimes feel rough and grainy. This is due to an infinitesimal electrical charge, which is absolutely harmless. However, if you are concerned about this, connect the ground terminal (see figure) with an external ground. When the unit is grounded, a slight hum may occur, depending on the particulars of your installation. If you are unsure of the connection method, contact the nearest Roland Service Center, or an authorized Roland distributor, as listed on the "Information" page.

Unsuitable places for connection

- Water pipes (may result in shock or electrocution)
- Gas pipes (may result in fire or explosion)
- Telephone-line ground or lightning rod (may be dangerous in the event of lightning)

Main features and uses

Main features

4-part audio looper

The MC-09's audio looper is like a small sampler designed for creating looped phrases. You can capture (record) an audio signal into each of the four parts.

You can also use the **merge function** to combine two or more parts, to create polyphonic loops.

* For each part, the maximum recording time is six seconds (approximately two measures at BPM = 80).

A new Loop Control function

By recording Loop Control settings in the step sequencer, you can produce a wide range of variations from a single loop.

Pitch playback

You can change the pitch of the loop playback. This lets you play the loop at pitches different from the original pitch.

Trigger playback

Parts you specify can be played back in sequence. This lets you create performances that are similar to what you would obtain by striking the pads of a sampler.

Divide times 16 playback

You can divide a loop into pieces, and then reassemble it and play it back. This lets you create new phrases that are completely different than the original loop.

DSP synthesizer

The MC-09 has a built-in synthesizer that gives you a wide range of sounds (tones) in categories such as Lead, Bass, and Rhythm, as well as four different effects (Filter, Isolator, Phaser, and Slicer).

A mode that simulates the vintage synthesizers often used in Techno styles has also been included.

(The MC-09 can also be used as a synthesizer module.)

16-step sequencer

Not only can you record the notes you input as performance data, but you can also spice up your performances by using the **effect controller** to cyclically change the effect settings, or by using **loop control** to change the way a loop is played back.

Audio input jacks (INPUT jacks)

Since the MC-09 provides INPUT jacks, you can combine the MC-09's sounds with performances (audio signals) from another device such as a CD, MD, or keyboard.

- Capture (record) a performance from an external device, and loop it
- Mix an audio signal with the sounds of the MC-09
- Apply effects to an audio signal

Process Patch function

The MC-09's "Process Patch" function can remember and play back actions concerned with things such as the selection of a pattern (a sound together with a phrase), or the capture of an audio loop. For example, all the steps and settings involved in creating a loop can be saved as a Process Patch. The next time you turn on the power, you can load this to reproduce the same state as before.

This is a convenient way to store the procedure by which a loop was created, or to set up for a live performance.

Save loops to memory card

Loops and patterns you create can be saved on a separately sold memory card.

Ways to use the MC-09

Here are some ways in which you can use the MC-09. Your creativity will take you even further!

As a DSP synthesizer

- Playing the MC-09 from the keyboard pads..... (p. 18)
- Playing the MC-09 from an external MIDI device used as a master keyboard..... (p. 63)

Use sound-on-sound to create loops

Combine a performance from a CD or MD connected to the INPUT jacks with the sounds of the internal DSP sequencer to create sound-on-sound..... (p. 32)

Use loops in a live performance

- Record hip-hop or techno loops in each part, and use the step [1]–[4] buttons to play them..... (p. 52)
- Change the playback pitch..... (p. 51)
- Divide a loop and change the playback order of the parts..... (p. 52)

Use the monophonic synthesizer to create polyphonic loops

- Layer performances of the internal DSP synthesizer (Loop Merge) to create polyphonic loops..... (p. 38)
- Adjust the pan of each track to create 3D output... (p. 36)

Use the MC-09 as an effects processor

- Cyclically modifying the effect settings..... (p. 45)
- Applying effects to audio from a CD or MD..... (p. 41)

Making connections

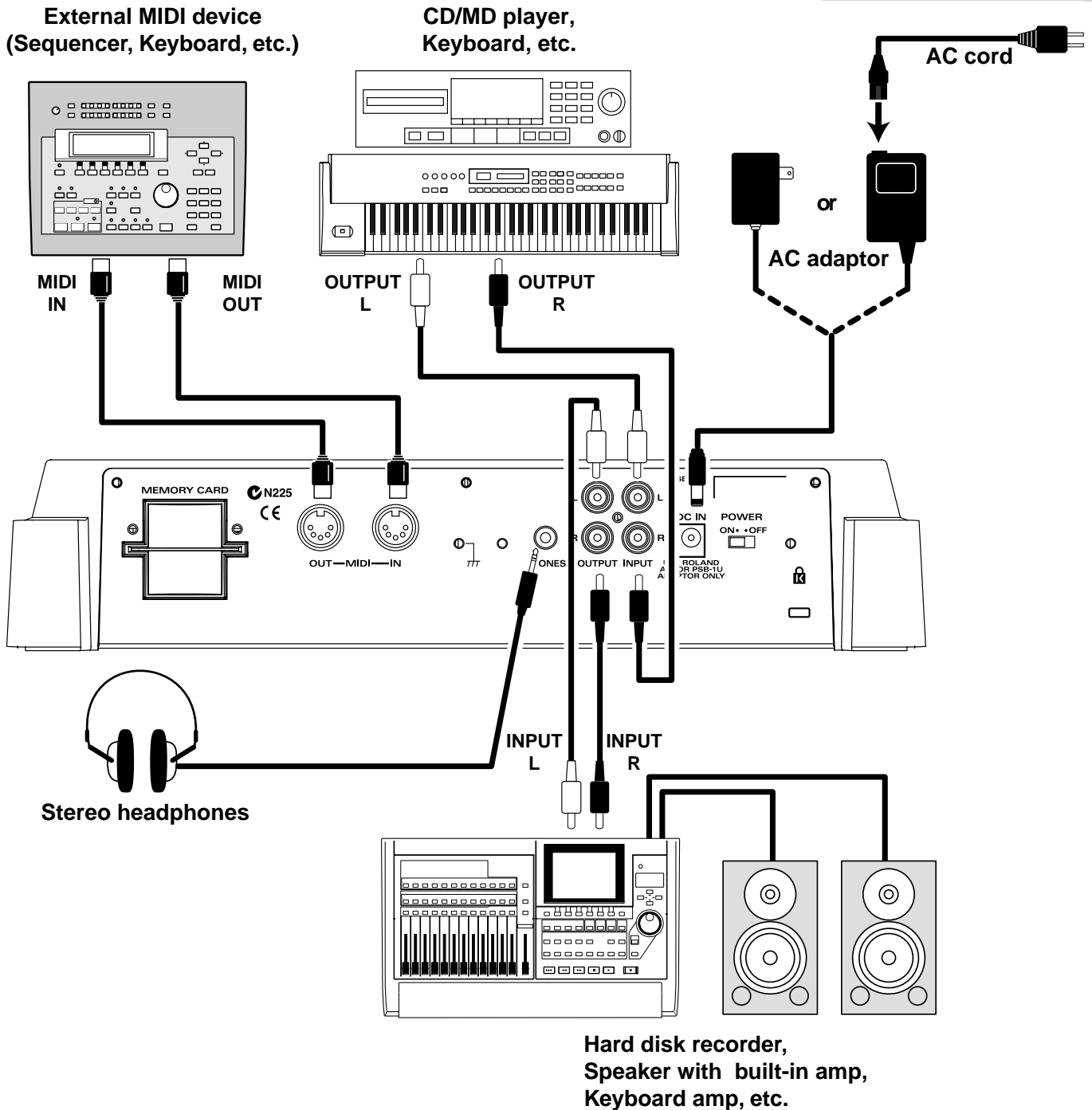

NOTE

- To prevent malfunction and/or damage to speakers or other devices, always turn down the volume, and turn off the power on all devices before making any connections.
- When connecting other equipment to the INPUT or OUTPUT jacks, be sure to use cables that do not have a built-in resistor (e.g., the Roland PCS series).

Turning the power on/off

Turning the power on



- Once the connections have been completed (p. 12), turn on power to your various devices in the order specified. By turning on devices in the wrong order, you risk causing malfunction and/or damage to speakers and other devices.
- This unit is equipped with a protection circuit. A brief interval (a few seconds) after power up is required before the unit will operate normally.
- Turn the volume down before you turn on the power. You may hear sound from the headphones when you turn on the power, but this is not a malfunction.

1

Make sure that the volume controls of the MC-09 and all connected devices are turned to the minimum position.

2

Turn on the power of the device connected to the INPUT jacks.

3

Turn on the power of the MC-09.

4

Turn on the power of the device connected to the OUTPUT jacks.

5

Adjust the volume of all devices.

On the MC-09, the volume is affected by three types of knob or control. You will need to adjust these as appropriate.

OUTPUT knob: This adjusts the overall volume of the MC-09.

LEVEL knob: This adjusts the volume from the device connected to the INPUT jacks and the volume of the DSP synthesizer.

Part volume sliders: These adjust the volume of each audio looper part.

** In some cases, there will be no sound if any of these knobs are set to the minimum position.*

Turning the power off

To turn off the power, make sure that the volume controls of the MC-09 and all connected devices are turned to the minimum position, and turn off the power of each device in the opposite order of that used when you turned them on.

Using the MC-09 as a synthesizer

—Playing and creating patterns

What is a pattern?

On the MC-09, a “pattern” is a phrase of one or two measures together with a sound to play that phrase. You can use the [▶](PLAY) button to play back a phrase, or use the keyboard pads to play manually.

Depending on how a pattern is played or the sound it uses, the patterns of the MC-09 are organized into three groups: LEAD, BASS, and RHYTHM. Each group contains preset patterns. You can also store original patterns that you create on a user memory (user patterns) or a memory card (p. 30).

LEAD: Patterns suitable for playing melodies

BASS: Patterns suitable for playing bass

RHYTHM: Patterns suitable for playing drums or percussion

A sound used by a pattern in the LEAD or BASS group is called a **Tone**, while the sounds used by a pattern in the RHYTHM group are called a **Rhythm set**. A rhythm set contains numerous **Rhythm Tones**, such as snare drum, hi-hat, and bass drum.

NOTE

All rights reserved.
Unauthorized use of this material for purposes other than private, personal enjoyment is a violation of applicable laws.

MEMO

For details on patterns, refer to “Sound List” (p. 76).

Preset Patterns

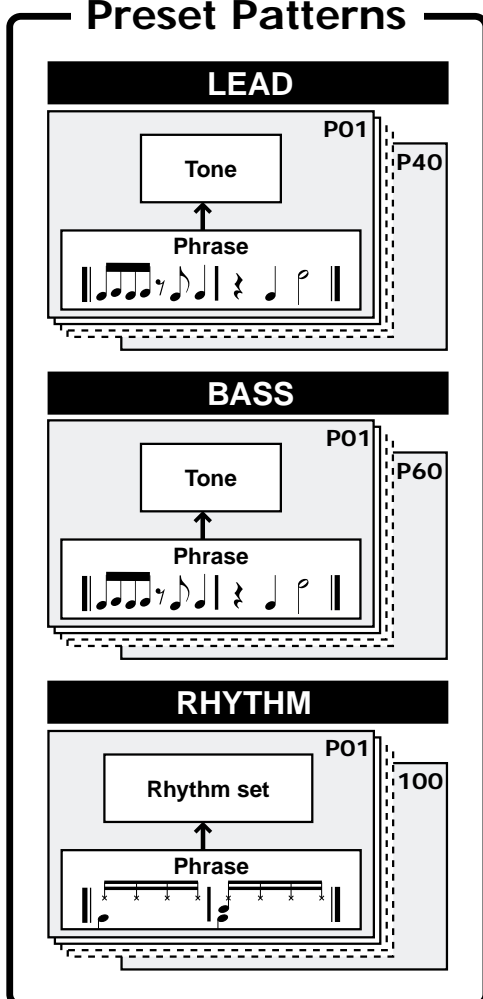

Your Own Patterns

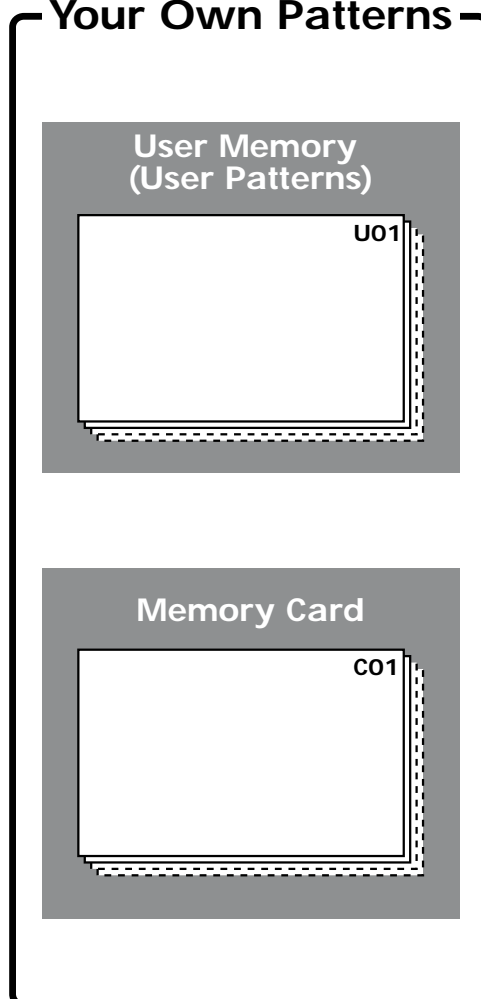

Playing

Playing a pattern

Plays the phrase in the pattern.

1

Turn on the power, and adjust the volume of each device in your setup (p. 13).

2

Make sure that the [LEAD] button's indicator is lit.

3

Make sure that the following appears in the display.

This display tells you that pattern "P01" of the LEAD group is selected.

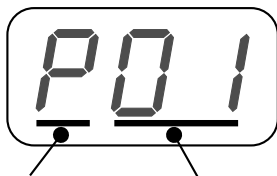

P: Preset pattern Pattern number
U: User pattern
C: saved pattern in memory card

4

Press the [▶](PLAY) button to play back the pattern.

The pattern will play repeatedly until it stops.

** If you press the [▶](PLAY) button after you've stopped playback midway through the pattern, playback will begin again from the beginning of the pattern. It is not possible to play back from the middle of a pattern.*

5

To stop the pattern, press the [■](STOP) button.



If you press the [▶] button when a loop has been recorded in the Audio Looper, the pattern and the loop will play back together. If you want to play only the pattern, you can lower the volume of the audio loop part (p. 35) or mute it (p. 36).



During pattern playback, the indicators of the step [1]-[16] buttons will light sequentially. This indicates the currently-sounding step.

Selecting a pattern

1

Press either the [LEAD], [BASS], or [RHYTHM] button to select the desired pattern group.

2

Make sure that the display shows the pattern number.

At this time, also make sure that the BPM, OCT, or TONE/TYPE indicators are not lit. If one of these indicators is lit, press the [DISPLAY] button until the indicator goes out.

3

Use the [INC] and [DEC] buttons to select a pattern.

“P” in front of the number indicates a preset pattern, “U” indicates a user pattern, and “C” indicates a pattern saved on a memory card.

You can rapidly switch between preset (P), user (U), and card (C) by holding down the [SHIFT] button and pressing the [INC] or [DEC] button.

* Depending on the pattern you select, the indicator of the [LEAD], [BASS], or [RHYTHM] button will blink, and the [LOOP CTRL] button's indicator may light (Loop Control: On). This indicates that the selected pattern includes Loop Control settings (p. 53).

4

When selecting a pattern from a card, or when switching to another pattern while the current pattern plays, press the [ENTER] button to finalize your selection.

The selected pattern number will blink until you finalize it.

* This step is not necessary when selecting a preset or user pattern while the pattern is stopped.

* You cannot select a pattern from a card during playback. In this case, the display will indicate “C--”.

MEMO

Pressing the [DISPLAY] button repeatedly cycles the indicators through the following states: dark → BPM → OCT → TONE/TYPE → dark → ...

NOTE

If you select a pattern for which Loop Control is turned on, you will not hear any sound if a loop has not been recorded in the audio looper (p. 53). Press the [LOOP CTRL] button to turn Loop Control off, and you will hear sound.

HINT

If you switch to a different pattern while the current pattern is still playing, playback will change to the newly selected pattern at the beginning of the next measure. However, the tempo of the previous pattern will be maintained.

Patterns in the LEAD group

Normally, it is not possible to apply effects to the pattern playback.

Instead, the preset patterns of the LEAD group already include either a overdrive, distortion, phaser, or slicer + ring modulator effect. To see which effect is included, hold down the [SHIFT] button and press the step [16] button (p. 21).

The display will appear as follows.

od.1 : Overdrive 1

od.2 : Overdrive 2 (without filter envelope keyfollow)

d5.1 : Distortion 1

d5.2 : Distortion 2 (without filter envelope keyfollow)

Ph.1 : Phaser 1 (A light phaser effect is obtained.)

Ph.2 : Phaser 2 (A light phaser effect is obtained. tempo sync)

Ph.3 : Phaser 3 (A deep phaser effect is obtained.)

Ph.4 : Phaser 4 (A deep phaser effect is obtained. tempo sync)

SL.1 : Slicer + Ring Modulator 1

SL.2 : Slicer + Ring Modulator 2 (tempo sync)

OFF : No effect applied

When you are finished and want to return to the previous screen, press the [EXIT] button.

You can change the type of effect that is included in the pattern (p. 21).

You can turn the C1, C2, and C3 knobs to modify the effect settings (p. 20).

Adjusting the tempo of a pattern

Since each pattern carries its own tempo setting, it will play according to this tempo.

1

Select a pattern.

2

Press the [DISPLAY] button so the BPM indicator lights.

The display will show the tempo of the current pattern.

3

Use the [INC] and [DEC] buttons to set the tempo.

The tempo can be set to anything from ♩ = 40 to ♩ = 240.



If you want to use only the ring modulator with SL1, turn the C1 knob to the far left.



You can have your patterns play in sync with the tempo of an external MIDI device (p. 64).



If you switch to another pattern while the previous pattern is still playing, the tempo of the previous pattern will be maintained.



As an alternative to using the [INC] or [DEC] buttons, you can set the tempo by pressing the [TAP] button at the desired timing (p. 57).

Playing the keyboard pads

The step [1]–[16] buttons can act as a keyboard. These buttons are collectively called the **keyboard pads**. They let you play the MC-09 like a synthesizer keyboard.

- * It is not possible to play chords when a pattern from the LEAD or BASS group is selected. When a pattern from the RHYTHM group is selected, you can play up to three rhythm tones simultaneously.
- * If you play the keyboard pads while a pattern is playing back, the currently-sounding note will be turned off, and the last-played note will take priority.



You can use an external MIDI keyboard to play a broader range of pitches than you can on the keyboard pads (p. 63).



If you want to play the keyboard pads without playing back a pattern, hold down the [SHIFT] button and press either the [LEAD], [BASS], or [RHYTHM] button, and then select the pattern. At this time, the indicators for the [LEAD], [BASS], and [RHYTHM] buttons will be blinking. To return to the normal state, hold down the [SHIFT] button once again and press either the [LEAD], [BASS], or [RHYTHM] button.

1

Select a pattern.

Make sure that the [KEYBOARD] button indicator is lit. If it is not lit, press the [KEYBOARD] button so it lights.

2

Press the keyboard pads to play them.

The keyboard pads work as described below.

When a pattern from the LEAD or BASS group is selected

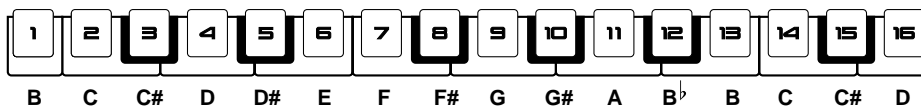

- * The Octave Shift setting will change the range of notes that you can play from the keyboard pads, as follows.

LEAD group

Octave Shift	Note range
-2	B1–D3
-1	B2–D4
0	B3–D5
1	B4–D6
2	B5–D7

BASS group

Octave Shift	Note range
-4	B-1–D1
-3	B0–D2
-2	B1–D3
1	B2–D4
0	B3–D5

(C4 = middle C)

When a pattern from the RHYTHM group is selected

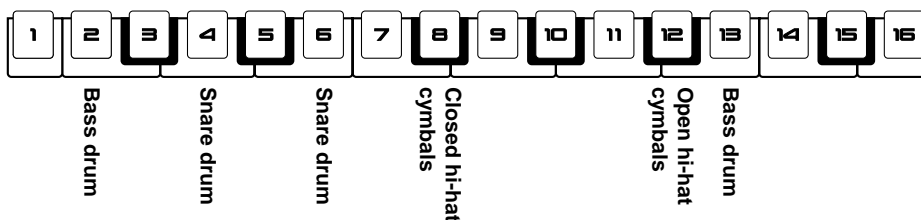

3

To change the Octave Shift setting, press the [DISPLAY] button enough times to get the OCT indicator to light, and then press the [INC] or [DEC] button.

The display will show the Octave Shift setting.

** If a pattern from the RHYTHM group is selected, it is not possible to change the Octave Shift setting.*

Mixing in a performance from a device connected to the INPUT jacks

The playback from a CD or MD connected to the INPUT jacks can be mixed with the performance of the MC-09's patterns, and output from the OUTPUT jacks.

1

Select a pattern.

2

Hold down the [SHIFT] button and press the [LINE IN] button.

Either the [LEAD], [BASS], or [RHYTHM] button indicator and the [LINE IN] indicator will light.

3

Play the pattern along with the performance from the CD or MD that is connected to the INPUT jack.

The pattern will be mixed with the performance from the CD or MD.

4

If you want to go back to playing only the pattern, hold down the [SHIFT] key once again and press the [LINE IN] button.



You can synchronize a pattern to the tempo of a CD or MD performance (p. 57). Press the display button so the BPM indicator lights, and then press the [TAP] button three or more times at the tempo of the CD or MD.

Modifying the sound

Using the knobs to edit the settings of the sound

You can use the six knobs to edit the sound settings in real time. The settings that can be modified by each knob will depend on the group of the selected pattern, as shown in the table below.

Group		C1	C2	C3	CUTOFF	RESO	DECAY
LEAD	Overdrive/ Distortion	Oscillator pitch	Depth of dis- tortion	Brightness	Cutoff frequency	Resonance	Filter envelope decay time
	Phaser	Modulation speed	Modulation depth	Resonance			
	Slicer + Ring mod- ulator	Interval to cut	Time to cut	Ring frequency			
BASS		Oscillator pitch	Filter enve- lope depth	Accent	Cutoff frequency	Resonance	Filter envelope decay time
RHYTHM		—	—	—	Bass drum volume	Snare drum volume	Hi-hat volume

Cutoff frequency: Specifies the frequency at which the filter will begin to be applied

Resonance: Emphasizes the region near the cutoff frequency

Decay time: Adjusts the time from the maximum level of the filter envelope until it reaches the sustain level

** If you use the knobs to edit the sound settings, your changes will remain in effect only while that pattern plays. The pattern will revert to the original settings when you select another pattern or turn off the power. If you want to keep the new settings, you must perform the Save operation (p. 30).*

Changing the sound of a pattern

Here's how you can change the tone or rhythm set used by a pattern.

1 Select a pattern.

2 Press the [DISPLAY] button enough times to get the TONE/
TYPE indicator to light.

The display will show the number of the tone or rhythm set that is assigned to the pattern.



The position of the knob may differ from the actual setting. In this case, turn the knob slightly, and then make the setting again.



For details on the function of each setting, refer to "Parameter list" (p. 68).



If you want to view the setting of a knob in the display while you adjust it, hold down the [SHIFT] button while you turn that knob.



If you want to check the setting of a knob in the display, hold down the [SHIFT] button and press the [DISPLAY] button. When you do this, the value of each knob will be displayed in the order of C1, C2, C3, CUTOFF, RESO, and DECAY.

3

Use the [INC] and [DEC] buttons to select a different tone or rhythm set.

When you switch tones, the knobs and other settings included in that tone will be reflected by the pattern. This means that the sound will be heard in a different way than for the original pattern.

* If you select a different pattern or turn off the power, the pattern will revert to its original tone or rhythm set. If you want to keep your new setting, you must carry out the Save procedure (p. 30).

Editing other sound settings

In addition to the settings of the six knobs, each tone has many other settings (parameters) that determine the resulting sound, and you can edit the values of these parameters.

* A rhythm set does not have any adjustable parameters other than the volume setting of each rhythm tone.

1

Select a pattern.

2

Hold down the [SHIFT] button and press one of the step [1]–[16] buttons to select the parameter whose value you want to adjust.

The display will show the value of the parameter you selected.

1	2	3	4	5	6	7	8	9	10	11	12	13	14	15	16
LFO rate	LFO waveform	OSC waveform	OSC vibrato depth	Filter type	Filter envelope attack time	Filter envelope sustain level	Filter envelope release time	Filter LFO depth	Amplifier envelope depth	Amplifier envelope attack time	Amplifier envelope decay time	Amplifier envelope sustain level	Amplifier envelope release time	Amplifier LFO depth	Effect type (LEAD) Vintage mode (BASS)



For an explanation of each parameter, refer to p. 68.

3

Use the [INC] and [DEC] buttons to adjust the value.

4

If you want to adjust the value of another parameter, press another step [1]–[16] button.

While you press the step [1]–[16] buttons, the display will show an abbreviation of the parameter name.

5

When you are finished making settings, press the [EXIT] button.

* These settings will revert to their original values if you select another pattern or turn off the power. If you want to keep your new settings, you must perform the Save operation (p. 30).

Adjusting the pan

Here's how to adjust the pan (stereo position) of a pattern.

1

Select a pattern.

2

Press the button of the selected group ([LEAD], [BASS], [RHYTHM]) once again.

The display will show "Pan" for a moment, then the pan setting.

3

Use the [INC] and [DEC] buttons to adjust the pan setting.

This can be adjusted in a range of L64 (left)-cnt (center)-R63 (right).

4

When you are finished adjusting the setting, press the [EXIT] button.

The display will return to the state in which it was before you began adjusting the pan.

** If you select a different pattern or turn off the power, the pattern will revert to its original pan setting. If you want to keep your new setting, you must carry out the Save procedure (p. 30).*

Adjusting the pitch

Here's how to adjust the pitch of a pattern. This is useful when you want to play back the pattern in a different key, or when you are playing together with a transposed instrument.

1

Press the [SETUP] button.

2

Press the [INC] or [DEC] button until the display indicates "tr5" (Transpose).

3

Press the [ENTER] button.

The display will show the transpose setting.

4

Use the [INC] and [DEC] buttons to adjust the transpose setting.

You can transpose the pitch in semitone steps over a range of one octave upward or downward. To raise the pitch one semitone, specify "1." To lower the pitch one semitone, specify "-1."

5

Press the [SETUP] button to complete the setting.

Creating a phrase (Recording)

You can step-input (record) a phrase of up to two measures. The MC-09 provides two recording methods. Use the method that is most appropriate for your situation.

* Notes are the only MIDI messages that can be recorded.

Step recording

In this method, you successively input the note for each step.

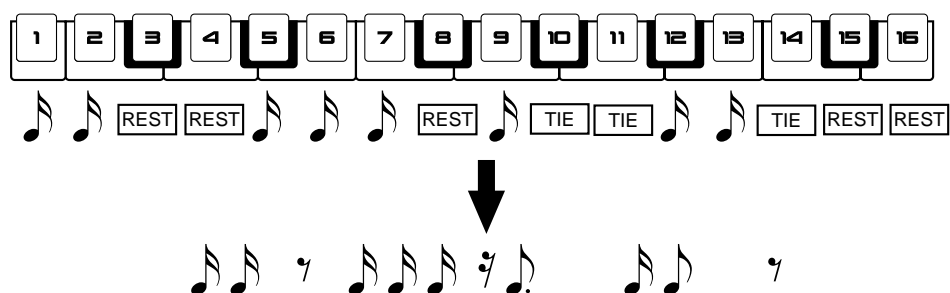

TR recording

In this method, you first specify the note that you want to input, and then “place” that note at the desired step while you listen to the playback.

This method is suitable for creating drum phrases, since you can input all notes for each rhythm tone (e.g., bass drum, snare drum, hi-hat) at once.

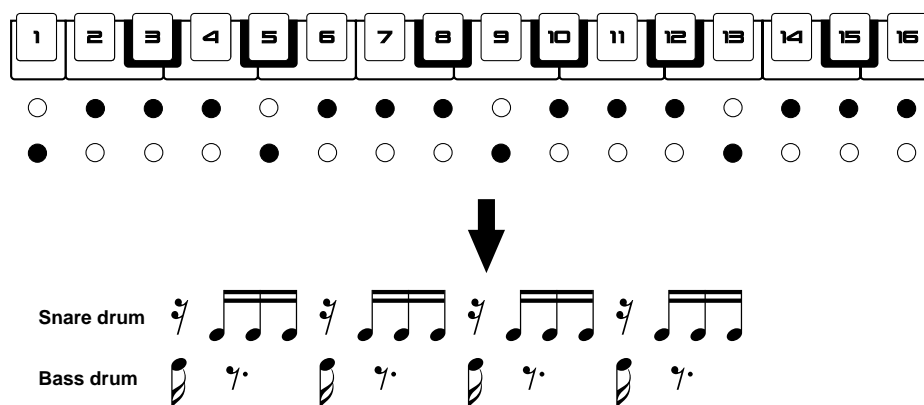

Preparations for recording

Whether you are using step recording or TR recording, the preparations are the same. Before you begin recording, you must specify the length of the phrase and the note value that you want to input.

* *The time signature of a phrase is fixed at 4/4, and cannot be changed.*

1

Select a pattern (p. 16).

If you want to use step recording, select a pattern from the LEAD or BASS group.

If you want to use TR recording, you may select a pattern from any group.

2

Adjust the sound as desired (p. 20).

3

Adjust the tempo as desired (p. 57).

4

Press the [SEQ REC] button.

The MC-09 enters Step Edit mode, allowing you to edit the phrase.

5

Press the [SETUP] button.

The MC-09 enters Setup mode, allowing you to make preparations for recording. The display will show the number of measures in the phrase.

6

Use the [INC] and [DEC] buttons to specify the number of measures in the phrase.

A phrase may have either one or two measures.

7

Press the [SCALE] scale button to specify the note value and the number of steps.

16th notes x 16 steps: indicator dark

8th note triplets x 12 steps: indicator lit

8

Press the [EXIT] button.

You're returned to Step Edit mode.



If you want to create a phrase from scratch, press the [REST] button in Setup mode to erase all steps.

9

You are now ready to record. Proceed to the recording method that you want to use.

- **Creating a melody or backing phrase**
→ Step recording (p. 25)
- **Creating a drum phrase**
→ TR recording (p. 27)

Creating a melody or backing phrase (Step Recording)

** Step recording is not possible if you've selected a pattern from the RHYTHM group.*

10

Make sure that the [KEYBOARD] button indicator is dark.

If it is lit, press the button to make it go dark.

11

Press a step [1]–[16] button to select the step at which you want to begin step recording.

If you are creating a new phrase, start step recording from step 1.

If you are step recording from the middle of an existing phrase, select the desired step.

** It is not possible to input two or more notes at one step. If you input a new note at the step in which a note has already been input, the existing note will be erased, and replaced by the new data.*

12

Press the [SEQ REC] button.

The display will briefly indicate "St.r" (Step Recording), and then step recording will begin.

The [KEYBOARD] button indicator will light. Now you can use the step [1]–[16] buttons as keyboard pads. The indicators of the step [1]–[16] buttons will light to indicate the step that is currently selected.

13

Use the C2 knob to adjust the velocity (volume) of the notes you enter, and the C3 knob to adjust the gate time (note duration).

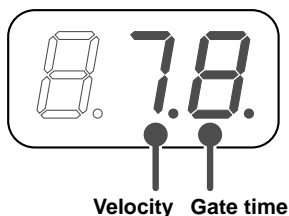

Velocity: 1-8

Gate time: 1-9, - (Slide-on)

Slide-on: The note of the current step will be smoothly connected to the note of the next step. Choose this when you want to simulate the playing technique used by guitar or bass players in which they slide their finger to another fret after plucking the string. This setting is available only if you've selected a pattern from the LEAD or BASS group.)

* It is not possible to specify the Gate Time if Vintage mode is turned on for a BASS group pattern.

14

To add an accent to a note, hold down the [SHIFT] button and press the [ACCENT] button.

The velocity value will blink.

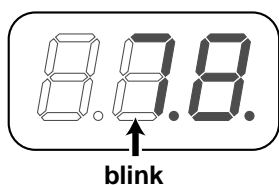

15

Press a keyboard pad to specify the note (pitch).

Once the pitch has been specified, you will advance to the next step.

16

Repeat steps 13-15 to create your phrase.

If you want to redo the settings of the previous step, press the [DEC] button to move backward to that step, and make the desired settings.

17

When you are finished creating the phrase, press the [■] (STOP) button.

Step recording will end, and you will return to Step Edit mode.

MEMO

Press the [TIE] button to input a tie, or the [REST] button to input a rest. When you press one of these buttons, the step will advance automatically, so you will not need to perform steps 14 and 15 of this procedure.

MEMO

You can also specify a slide-on by holding down the [SHIFT] button and pressing the [SLIDE] button.

HINT

While a BASS group pattern is playing, you can use the C3 knob to adjust the accent level.

MEMO

To change the range (octave shift) of the keyboard pads, press the [DISPLAY] button enough times to get the OCT indicator to light, and use the [INC] or [DEC] buttons.

MEMO

If you specified the length of the phrase as two measures, you can hold down the [SCALE] button to view the current measure position in the display. The previous display will reappear when you release the button.

18

To exit Step Edit mode, press the [EXIT] or [■] (STOP) button.

Creating a drum phrase (TR Recording)

10

Press the [▶](PLAY) button.

The display will briefly indicate "tr.r" (TR Recording), and then TR Recording will begin.

11

Make sure that the [KEYBOARD] button indicator is dark.

If it is lit, press the button to make it go dark.

12

Use the C1 knob to specify the rhythm tone.

Rhythm tone	Display
Bass drum	b
Snare drum	S
Closed hi-hat	C
Opened hi-hat	o

13

Use the C2 knob to adjust the velocity (volume).

If you are creating a non-drum phrase (i.e., if you've selected a pattern from the LEAD or BASS group), use the C3 knob to adjust the gate time (note duration) in the same way as for step recording.

* *It is not possible to specify the Gate Time if Vintage mode is turned on for a BASS group pattern.*

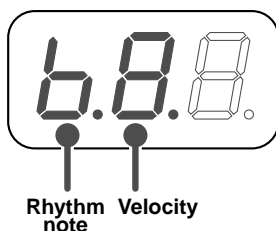

These pages use the example of creating a drum phrase to explain TR Recording, but you can also use TR Recording to create melody or backing phrases. In this case, read references in this explanation to “rhythm tone” as “note.”



If you want to use the keyboard pads to specify the rhythm tone, press the [KEYBOARD] button so its indicator lights. After you've specified the rhythm tone, press the [KEYBOARD] button once again so the indicator goes out.



If you want to change the range (Octave Shift) of the keyboard pads, press the [DISPLAY] button enough times to get the OCT indicator to light, and then press the [INC] or [DEC] button.



You can press the [TIE] button to input a tie, or the [REST] button to input a rest. However, it is not possible to input a rest while a RHYTHM group pattern is selected.

14

If you want to add an accent to a note, hold down the [SHIFT] button and press the [ACCENT] button.

The velocity value will blink.

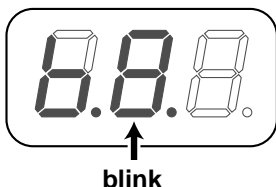

HINT

While a BASS group pattern is playing, you can use the C3 knob to adjust the accent level.

15

Use the step [1]–[16] buttons to select the step(s) at which you want to input a note.

You may select more than one step.

To erase a note you input, press the button for the corresponding step so the indicator goes out.

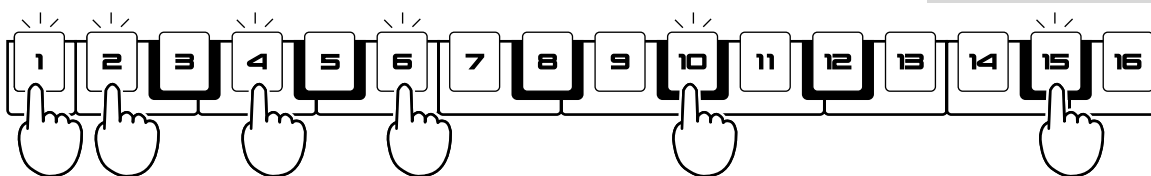

* If you selected a pattern from the RHYTHM group, you will be able to input up to three notes at each step. If you selected a pattern from the LEAD or BASS group, only one note can be input at each step. If you select a step for which a note has already been input (i.e., a step whose indicator is blinking), the previous data will be replaced by the new data.

16

While listening to the repeated playback, repeat steps 12–15 to create your phrase.

While you are recording, the phrase will play back repeatedly. Whenever you input notes, they will be reflected in the playback.

17

When you are finished creating your phrase, press the [■] (STOP) button.

TR Recording will end, and you will return to Step Edit mode.

18

To exit Step Edit mode, press the [■] (STOP) or [EXIT] button.

MEMO

The MC-09 remembers the settings you've input most recently (rhythm tone, velocity, etc.). If you want to use the same settings for the next note you input, you don't have to change the settings.

MEMO

If you specified a two-measure phrase and want to change measures, press the [SCALE] button to make the display show the measure number, and press the [INC] or [DEC] button. To see the current measure location, press and hold the [SCALE] button. The previous display will reappear when you release the button.

Editing a phrase

1

Select the pattern that contains the phrase you want to edit (p. 16).

2

Press the [SEQ REC] button.

The display will briefly indicate "St.E" (Step Edit), and then you will enter Step Edit mode.

The display will show the status of the currently selected step.

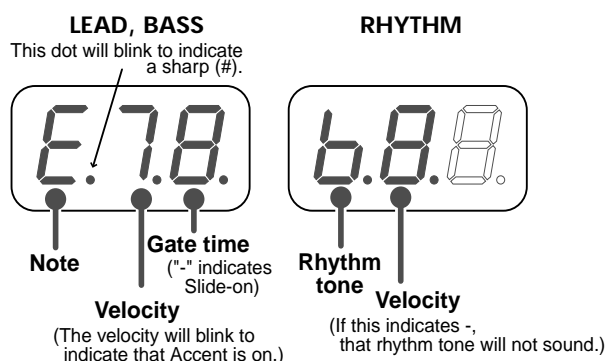

3

Make sure that the [KEYBOARD] button indicator is dark.

If it is lit, press the button to make it go dark.

4

Use the step [1]–[16] buttons to select the step(s) that you want to edit.

If you want to make the same settings for two or more steps, hold down the step button you pressed first and then press the buttons for the other steps.

5

Use the C1, C2, and C3 knobs to edit the settings of the note.

When you edit the note, the display will briefly show the note name.

C1 knob	C2 knob	C3 knob
Note (Rhythm tone)	Velocity	Gate time

* It is not possible to specify the Gate Time if Vintage mode is turned on for a BASS group pattern.

6

When you've finished editing, press the [■] (STOP) or [EXIT] button.

You will exit Step Edit mode.

MEMO

If you set the phrase length to two measures, you can change the measure position by pressing the [SCALE] button to make the display show the measure number, and then pressing the [INC] or [DEC] button. To check the current measure location, press and hold the [SCALE] button. When you release the button, the previous display will reappear.

MEMO

To use the keyboard pads to specify the tone (rhythm tone), press the [KEYBOARD] button so its indicator lights. When you've finished specifying the note (rhythm tone), press the [KEYBOARD] button once again so the indicator goes out.

MEMO

Press the [TIE] button to change a tie, or the [REST] button to change a rest.

Saving a pattern

If you've modified the contents of a pattern by editing the tone settings or by recording, you must save the pattern if you want to keep it.

- * *All your changes will be lost if you select a different pattern or turn off the power before you save the pattern.*
- * *The Save operation cannot be performed while a pattern is playing.*

The following data is saved

- Tone/Rhythm set
- Pan
- Parameter settings (including the settings of the six knobs)
- Phrase
- Loop control settings (p. 56)
(If loop control settings are not included)

1

Press the [WRITE] button.

The pattern number in the display will blink.

2

Use the [INC] and [DEC] buttons to select the save-destination pattern number.

Select U01–U20 if you want to save to internal memory, or C01–C50 if you want to save to a memory card.

- * *Since the data you save will overwrite any previous data at that location, the previous data will be lost. Make sure that the selected number does not contain a pattern you want to keep.*

3

Press the [WRITE] button to execute.

The display will indicate “Sur”, asking you to confirm the operation.

4

Press the [WRITE] button to write.

While a pattern is being saved, the display will show “bsy”. When the data has been saved, you will return to the screen in which you were prior to beginning the Save process.

- * *If you decide not to save the pattern, press the [EXIT] button.*



You can save 20 patterns (total for LEAD, BASS, RHYTHM, and EFFECTS groups) in internal memory.

Creating and playing a loop

What is a loop?

The audio looper has four parts: parts 1 through 4. Each part can record (capture) a performance from the DSP synthesizer (a pattern from the LEAD, BASS, or RHYTHM group), or an external audio input. The data recorded in each part is called a **loop**.

These loops will play back repeatedly (i.e., “loop”) in synchronization to a standard tempo. You can play all four loops simultaneously, or play just a specific part.

For part 1, you can use a variety of editing and control functions (Loop Control) to create even more sophisticated loops.

You can combine your favorite drum breaks and bass lines as a loop, and take advantage of the Loop Control function to create new songs with different types of groove. This gives you enormous potential for creating remixes.

MEMO

The captured loop will be monaural.

MEMO

For details on the standard tempo, refer to “About the tempo” (p. 57).

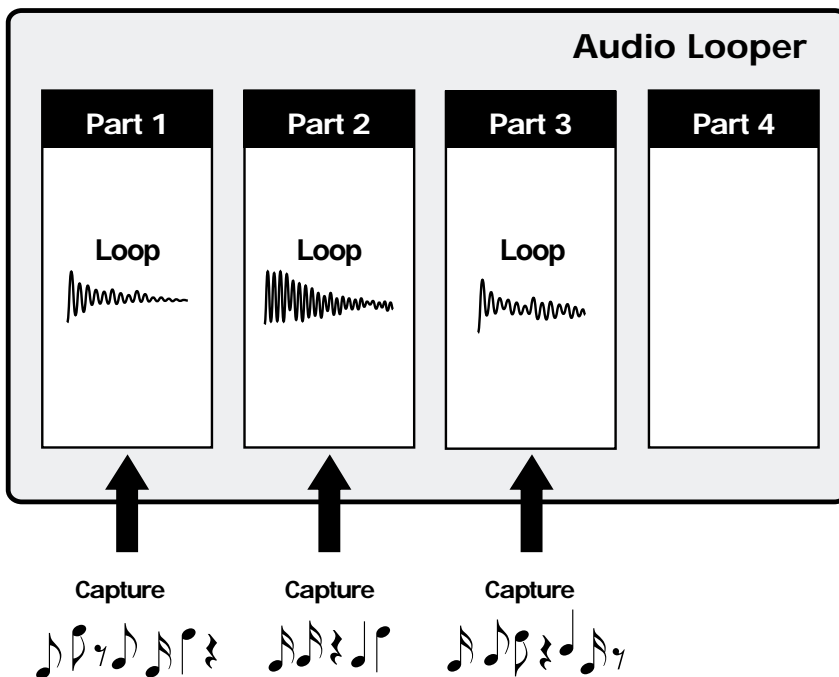

The process of creating a loop

This page outlines the process of creating a loop.

1. Make preparations for capture

Capturing the performance of a pattern

- (1) Select a pattern (p.16)
- (2) Set the tempo (p.17)
- (3) Adjust the sound (p.20)

Capturing a performance from an external device

- (1) Press the [LINE IN] button
- (2) Adjust the volume of the device connected to the INPUT jacks
- (3) Set the tempo (p.57)

Capturing the performances of a pattern and an external device

- (1) Select a pattern (p.16)
- (2) Hold down the [SHIFT] button and press the [LINE IN] button (p.19)
- (3) Set the tempo (p.17)
- (4) Adjust the sound (p.20)

Capturing while you apply an effect to a performance of an external device or a loop

- (1) Press [EFFECTS] to turn effects on (p.42)
- (2) Specify what the effect is to be applied to (p.41)
- (3) Select an effect pattern (p.42)
- (4) Make effect settings (p.43)
- (5) Set the tempo (p.57)
- (6) When applying an effect to a loop, use the part level knob to adjust the volume (p.35)

Capturing a loop control performance

- (1) Select a effect pattern (p.42)
 - (2) Press the [LOOP CTRL] button to turn Loop Control on (p.54)
 - (3) Make loop control settings (p.54)
 - (4) Set the tempo (p.57)
- * If all parts are being used with Loop Control, you will not be able to perform a capture.

2. Begin recording the process patch (p.39)

Hold down the [SHIFT] button and press the [PROCESS] button.

* Perform these steps as necessary.

3. Capture (p.33)

4. Adjust the volume balance of the parts (p.35)

5. Apply effects (p.41)

6. Edit the settings of part 1 (p.37)

7. Merge loops (p.38)

8. Save the process patch (p.40)

* Save the process patch if you performed step 2.

9. Save the loop to a memory card (p.59)



When capturing to each part, you should ensure that the pattern and the external device(s) use the same tempo. If each performance you capture has a different tempo, the timing may fail to match when you play back the loop.



If you turn an effect on, you will not be able to capture the performance of the parts for which the effect is not turned on.



If you are recording the loop control performance together onto a single part, you can get the same results by using Loop Merge.



You can also apply an effect to a loop control performance and capture it to another part.

Recording (capturing)

The action of recording into the audio looper is called **capturing**. You can capture up to six seconds of sound in each part.

1

Turn the [LEVEL] knob to adjust the capture volume.

2

Press the [CAPTURE] button.

The indicators for the [CAPTURE] button will light, and the [SEL] buttons of each part will blink, indicating that the MC-09 is ready to capture.

3

Press a [SEL] button to select the part into which the sound is to be captured.

The indicator of the [SEL] button for the part you selected will light, and the indicators for the [CAPTURE] button will blink.

** If you capture to a part that has already been captured, the previous contents will be erased, and replaced by the new sound.*

4

Press the [SETUP] button and then press the [INC] or [DEC] button to make Capture Quantize settings (see next page). When you are finished making Capture Quantize settings, press the [SETUP] button.

1: Automatically stop capture after the first measure

2: Automatically stop capture after the second measure

OFF: Stop capture when you press the [■](STOP) button

5

Press the [CAPTURE] button to start capture.

If other parts have already been captured, those parts will also begin playing. If you do not want other already-captured parts to play, press their [STATUS] button to make the indicator blink.

6

Stop capturing.

If Capture Quantize is turned "OFF," capture will stop at the moment you press the [■](STOP) button. If Capture Quantize is set to "1" or "2," capture will stop automatically according to the setting.

If you started capture while the loop was playing, loop playback will continue. To stop loop playback, press the [■](STOP) button.

** Capture will stop automatically after six seconds, regardless of the Capture Quantize setting.*

MEMO

Normally, the [LEVEL] knob adjusts the volume of the audio signal of the DSP synthesizer, or the input from the INPUT jacks. However, when you are capturing, the [LEVEL] knob adjusts the capture volume.

MEMO

The state of each part is shown by the indicators of the [STATUS] buttons. Parts that have been captured: lit or blinking
Parts that have not been captured: dark

MEMO

If you want to abort the capture procedure, press the [EXIT] button.

MEMO

You may begin capturing even while a loop is playing. In this case, capture will begin when the playback returns to the beginning of the loop after you pressed the [CAPTURE] button.

Correcting the length of the loop (Capture Quantize)

The timing at which you stop capture is an important factor in creating a precise loop. If you stop capturing at the wrong time, the loop length and the timing of the measures in the pattern will be skewed, and it will not be possible to synchronize the loop accurately. To prevent this, you can automatically stop capture at the moment the first or second measure ends, relative to the current tempo. This is called **capture quantize**.

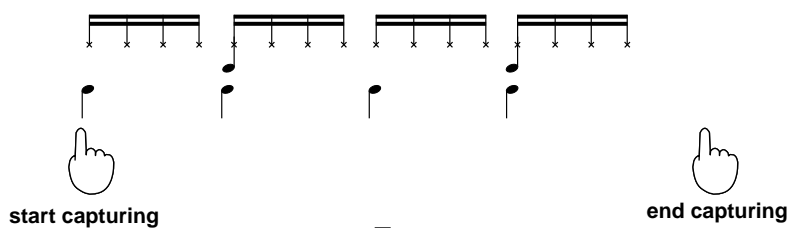

Set the value of the capture quantize at 1.

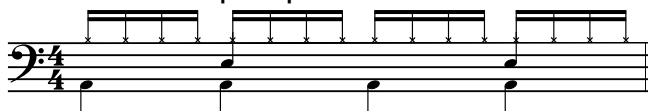

Set the value of the capture quantize at 2.



Set the value of the capture quantize at OFF.



Auditioning a loop (Preview)

Here's how you can preview each part of the recorded loop.

1

Make sure that a pattern or effect control is not playing.

If any of these are playing, press the [■] (STOP) button to stop them.

2

Press the [SEL] button of the part that you want to hear.

The loop will play while you hold down the button. However, it will not play back repeatedly.

Playback

1

Press one of the following buttons to select how you want playback to occur. Then select the pattern or effect pattern that you want to play.

Button	Playback method
[LINE IN]	Play back a loop by itself
	Play back a loop together with an external device
[LEAD], [BASS], [RHYTHM]	Play back a pattern and loop together
[SHIFT] + [LEAD], [BASS], [RHYTHM]	Play the keyboard pads together with the loop playback (don't play the pattern phrase)
Select [LEAD], [BASS], [RHYTHM], then [SHIFT] + [LINE IN]	Play back a pattern and loop together with an external device
[EFFECT]	Play back a loop while applying an effect (p. 41)
[LOOP CTRL]	Modify the way in which a loop plays back (p. 53)

2

To begin loop playback, press the [▶](PLAY) button.

* When you press the [▶](PLAY) button, playback will always start from the beginning of the loop. It is not possible to play back from the middle.

3

To stop loop playback, press the [■](STOP) button.

The loop will continue playing back repeatedly until you press the [■](STOP) button.

Adjusting the volume balance of the parts

Use the part level sliders to adjust the volume balance.

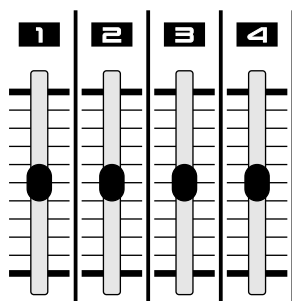

MEMO

If you've selected a pattern, effect pattern, or loop control pattern, it will play/stop in synchronization with the loop.

HINT

To check the number of measures in the loop, press the [DISPLAY] button so the TONE/TYPE indicator lights, and then press the [SHIFT] button and [STATUS] button.

In this state, you can use the [INC] or [DEC] buttons to change the number of measures in the loop.

MEMO

If you are playing the loop together with a pattern, use the [LEVEL] knob to adjust the volume of the pattern. Use the [OUTPUT] knob to adjust the overall volume.

HINT

The position of the sliders may differ from the actual setting. In this case, slide the sliders slightly, and then make the setting again.

Muting or un-muting a part

When you press the [▶] (PLAY) button to play back a loop, all captured loops will normally be heard. However, you can use the Mute function to mute (silence) specific parts.

1

Press the [STATUS] button for the part that you do not want to hear, so it is blinking.

The indicators will show the status of each part.

Lit: the part will play

Blinking: the part will not play (Muted)

Dark: no sound is recorded

2

To defeat muting, press the [STATUS] button once again.

Adjusting the pan

You can adjust the pan (stereo position) of the loop playback.

1

Press the [PAN] button so its indicator lights.

2

Press the [SEL] button of the part whose pan you want to adjust.

3

Use the [INC] and [DEC] buttons to adjust the pan.

You can adjust the pan in a range of L64 (left)–cnt (center)–R63(right).

4

When you are finished adjusting the pan, press the [PAN] or [EXIT] button.

Applying effects

Refer to  (p. 41).

Changing the tempo

Refer to  (p. 57).

When you change the tempo of a loop, the pitch will change correspondingly. Speeding up the tempo will raise the pitch, and slowing down the tempo will lower the pitch. This is the same as what happens when you change the speed of a tape recorder. However, if a pattern and loop are being played simultaneously, the pitch of the pattern will not change.

* *If you change the tempo of a loop so that it is less than half or more than double the tempo at which it was captured, the transition between repeats may not occur smoothly.*

MEMO

The captured loop will always be monaural.

MEMO

To check the tempo at which the loop was captured, press the [DISPLAY] button so the BPM indicator lights, and then simultaneously press the [SHIFT] button together with the [STATUS] button of the desired part.

Changing the settings of part 1

You can change the playback pitch and playback region of the sound that you captured in part 1.

C1 knob	C2 knob	C3 knob
Playback pitch	Location at which the sound will begin (Position)	Length at which the sound will begin (Length)

Playback pitch: This changes the pitch of the loop. Raising the pitch will speed up the playback tempo of the loop, resulting in a silent portion. Lowering the pitch will slow down the playback tempo of the loop, so that the loop will not play all the way to the end.

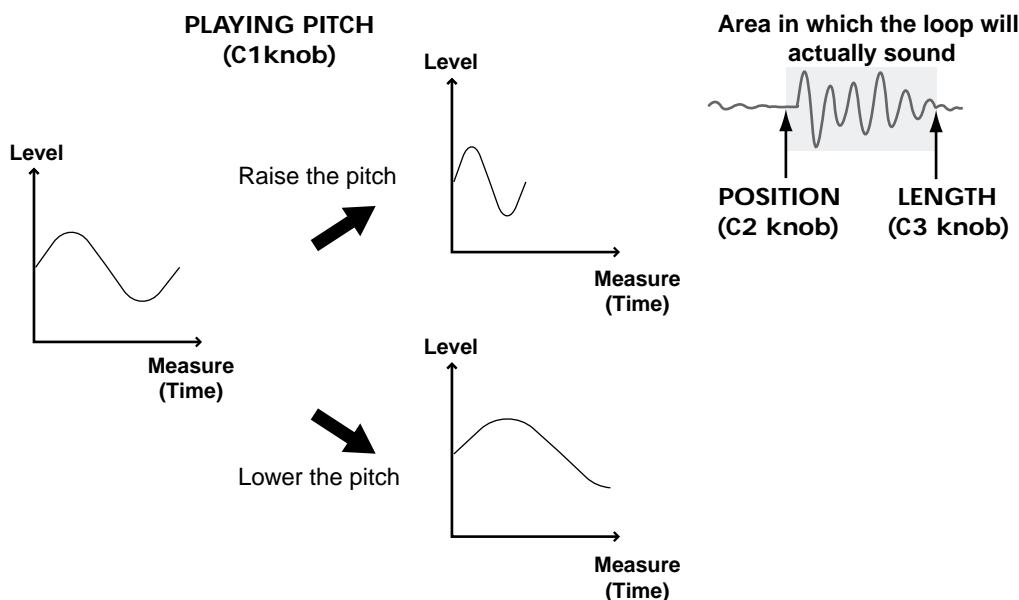

The position of the sliders may differ from the actual setting. In this case, slide the sliders slightly, and then make the setting again.



Once you change the settings of part 1, it is not possible to return them to their original state. You can lock these settings so that they cannot be accidentally rewritten. To lock the settings, press the [ENTER] button so the [EDIT1] button's indicator is blinking. To unlock the settings so that they can be adjusted, press the [ENTER] button once again so the [EDIT1] button's indicator lights solidly.

- 1 To begin loop playback, press the [▶] (PLAY) button.
- 2 Press the [EDIT1] button.
Now you can adjust the settings of part 1.
- 3 Turn the C1–C3 knobs to adjust the settings while listening the loop.
- 4 Press the [EDIT1] button or the [EXIT] button to return to the normal playing mode.
- 5 To stop loop playback, press the [■] (STOP) button.

Combining several parts into one (Loop Merge)

You can free up additional parts by combining several previously recorded parts into a single part. This is called **loop merge**.

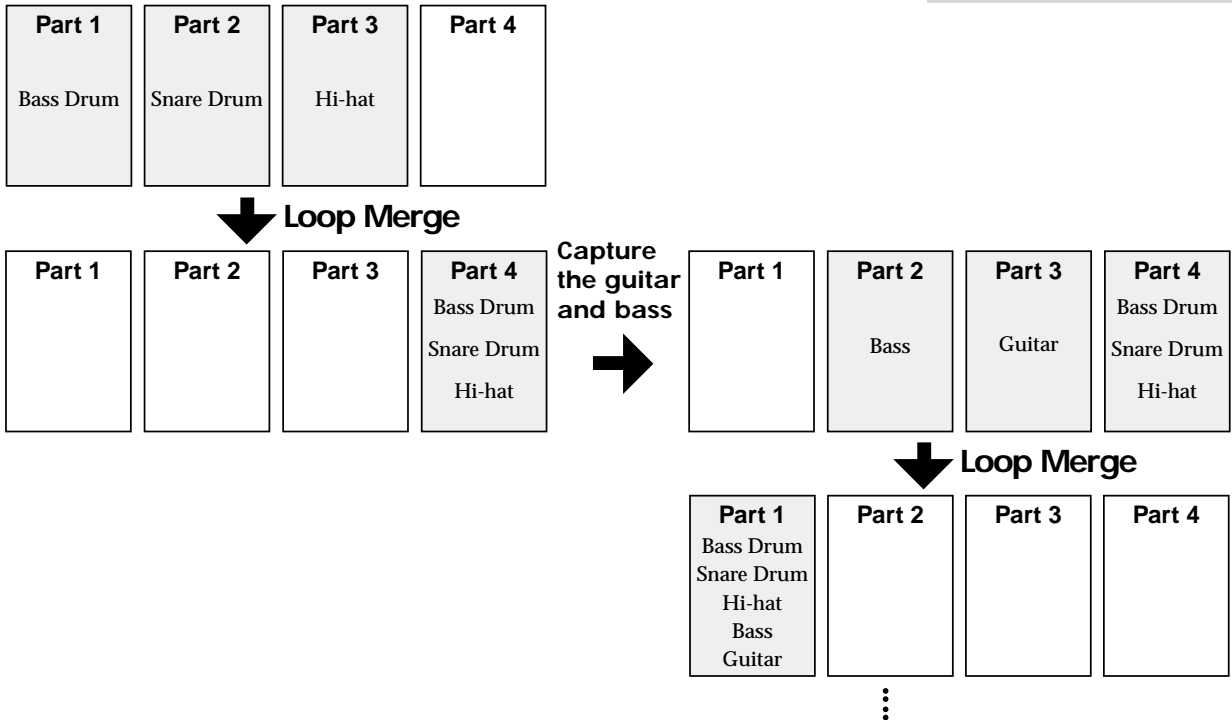

- * You must have an empty part in order to perform Loop Merge.
- * Adjust the desired volume balance (p. 35) among the parts before you perform Loop Merge. It is not possible to readjust the volume balance once you've performed Loop Merge.
- * Pan settings will not be merged.
- * If you execute Loop Merge with the effect turned on, the effect will be applied to the sound you hear during loop merge, but will not be reflected by the part after loop merge.

1

Press the [LOOP MERGE] button.

The FROM indicator will light, and the indicators of [SEL] buttons for which a capture has been carried out will blink.

2

Press two or more [SEL] buttons to select the parts that you want to combine into one.

The [SEL] button indicators of the selected parts will light.

3

Press the [LOOP MERGE] button.

The To indicator will light, and the [SEL] buttons of the parts you did not select in step 2 will blink.

4

Press a [SEL] button to choose the part into which the other parts will be combined.

The [SEL] button of the selected part will light, and the [LOOP MERGE] button indicator will blink.

** Be aware that if you select an already-captured part, the existing content will be erased and overwritten by the loop-merged content.*

5

Press the [LOOP MERGE] button to begin the Loop Merge operation.

While loop merge is occurring, the [LOOP MERGE] button indicator will light. When the indicator goes dark, loop merge has been completed.

Erasing the contents of a part

Here's how you can erase a captured part that you no longer want.

1

Simultaneously hold down the [SEL] button and [STATUS] button of the part whose contents you want to erase.

Saving the steps by which you created a loop (Process Patch)

You can save the steps by which you created a loop or made pattern settings. This is called a **process patch**. When you play back a process patch, the operations you performed when creating the loop will be performed once again, reproducing the loop.

When you turn on the power, the MC-09 automatically begins remembering the button operations you perform. A process patch can record up to eleven operations. If you perform more than eleven button operations, the oldest operations will be successively discarded, and the newly performed operations will be remembered.

If you want to create a new process patch, hold down the [SHIFT] button and press the [PROCESS PATCH] button to erase all recorded button operations.

By creating a loop skillfully, you can create an effective process patch that will produce loops with greater repeatability.



You can also store loops on a memory card (p. 59). However, this saves only the performance (audio data) recorded in each part, and does not save pattern settings or pan settings you made when creating the loop.

Creating and playing a loop

Contents that are saved in a process patch

- Eleven most recent button operations
- Settings of the pattern when you captured it
- Capture volume
- Settings of part 1
- Loop merge From and To parts
- Pattern settings when you saved the process patch
- Pan settings when you saved the process patch

Contents that are not saved in a process patch

- Audio data
- Realtime operations of the knobs
Only the last setting will be saved. Movements will not be recorded.
- Performances of an external MIDI device
- Part volume settings when you saved the process patch
- Mute data for each part

Saving a process patch

* *Process patch settings are temporary. If you want to keep a process patch, you must save it. A process patch that has not been saved cannot be played.*

1

Press the [PROCESS PATCH] button.

The indicator will light, and the display will indicate "Prc."

* *If you decide to abort the Save process, press the [EXIT] button or the [PROCESS PATCH] button.*

2

Press the [WRITE] button.

The display will ask you if you really want to save the settings (Sur).

3

Press the [WRITE] button to save the settings.

While the settings are being saved, the display will indicate "bsy." When saving has been completed, you will return to the screen in which you were before beginning the Save operation.

* *If you want to abort the Save operation, press the [EXIT] button.*

Playing back a process patch

1

Press the [PROCESS PATCH] button.

The indicator will light, and the display will indicate "Prc."

2

Press the [▶](PLAY) button.

The contents that were saved in the process patch will be played back consecutively. When the entire contents have been played back, the process patch will automatically stop playing.

If you want to stop playback of the process patch before it has finished, press the [■](STOP) button.

* *When you play back a process patch, the loop you are currently creating, and any unsaved process patch will be lost.*

MEMO

One process patch can be saved in the internal memory of the MC-09. You can also store patches on an external MIDI device (p. 65).

HINT

To check the content of the process patch before you save it, press the [PROCESS PATCH] button so its indicator lights, then press the [ENTER] button. When you do this, a loop will be created according to the current process patch contents.

This will not affect the process patches that are already saved.

Applying an effect

The MC-09 offers four effects: **filter**, **isolator**, **phaser**, and **licer**. You can select one of these and apply it to the external input or a loop.

Specifying the effect routing

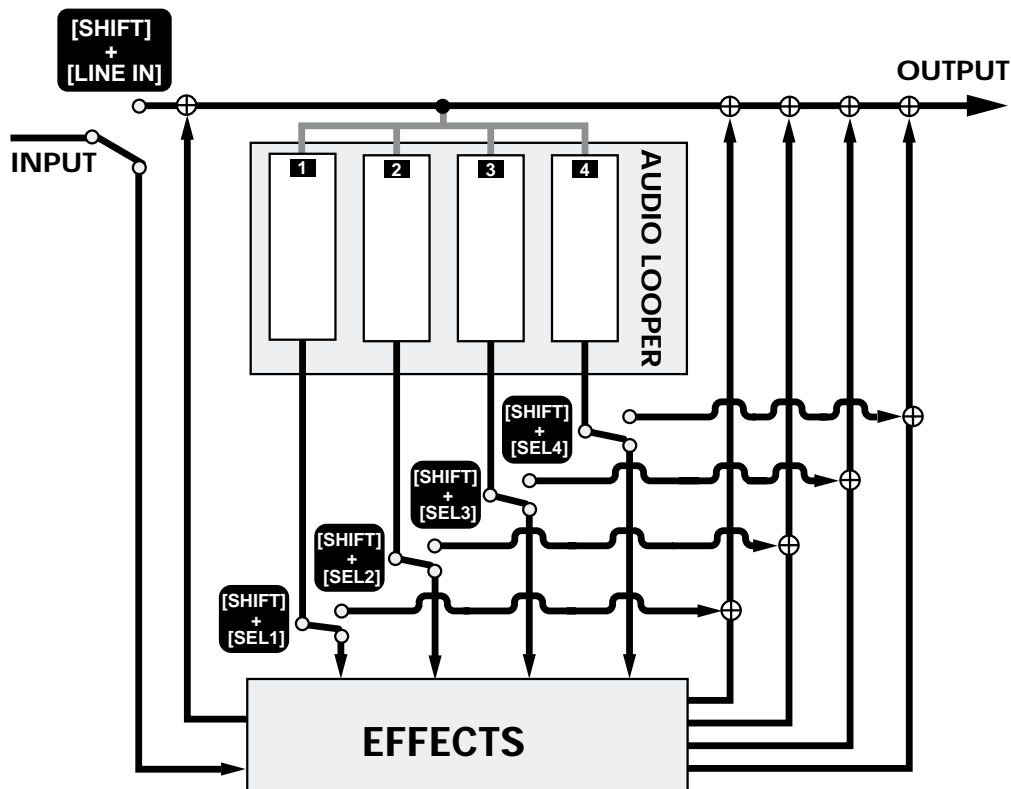

HINT

It is not possible to apply an effect if you've selected a pattern from the LEAD, BASS, or RHYTHM groups. To obtain the same result, you can capture the pattern playback and then apply an effect.

MEMO

The effect routing will be remembered until you turn off the power.

MEMO

When you press the [EFFECTS] button for the first time after turning on the power, the effect will be applied to the external input and to all parts.

1

Press the [EFFECTS] button.

2

Hold down the [SHIFT] button and press the [LINE IN] button to specify whether the effect will be applied to the external input.

[LINE IN] button indicator lit: The effect will be applied to the external input

[LINE IN] button indicator blinking: The effect will not be applied to the external input

3

Hold down the [SHIFT] button and press the [SEL] button of a part to specify whether the effect will be applied to that part.

[SEL] button indicator lit: Apply the effect to the part

[SEL] button indicator blinking: Don't apply the effect to the part

Turning the effect on/off

1 Press the [EFFECTS] button so its indicator lights.
The effect will be turned on.

2 To turn off the effect, press the [EFFECTS] button to make the indicator blink.

Rapidly switching the effect on/off

You can use the **effect grab function** to rapidly switch the effect on/off, as is sometimes done in a DJ performance.

1 Make sure that the [EFFECTS] button's indicator is lit or blinking.
If it is not lit or blinking, press the [EFFECTS] button.

2 Hold down the [SHIFT] button and press the [EFFECTS] button.
The effect will be on while you hold down both buttons.

3 Continue to hold down the [SHIFT] button, and release the [EFFECT] button to turn the effect off. If you release the [SHIFT] button and then release the [EFFECT] button, the effect will remain on.

Selecting an effect pattern

When using an effect, you can have the effect settings change along with the performance. Such a group of effect settings are called an **effect pattern**. The MC-09 contains 30 effect patterns for immediate use. You can also create your own effect patterns and save them in internal memory or on a memory card.

Filter: Modify the brightness

Isolator: Boost/cut specific frequency regions

Phaser: Modulate the sound

Slicer: Intermittently cut the sound

1 Press the [EFFECTS] button.

2 Make sure that the display indicates an effect pattern number.

Also make sure that none of the BPM, OCT, or TONE/TYPE indicators are lit. If one of these indicators is lit, press the [DISPLAY] button several times, until the indicator goes out.



The effect on/off setting will be remembered until you turn off the power.

3

Use the [INC] and [DEC] buttons to select an effect pattern.

“P” in front of the number indicates a preset effect pattern, “U” indicates a user effect pattern, and “C” indicates an effect pattern saved on a memory card. You can rapidly switch between preset (P), user (U), and card (C) by holding down the [SHIFT] button and pressing the [INC] or [DEC] button.

4

When selecting an effect pattern from a card, or when switching to another effect pattern while the current effect pattern plays, press the [ENTER] button to finalize your selection.

The selected pattern number will blink until you finalize it.

- * This step is not necessary when selecting a preset or user effect pattern while the pattern is stopped.
- * You cannot select an effect pattern from a card during playback. In this case, the display will indicate "C--".

Using the knobs to adjust the effect settings

Use the C1, C2, and C3 knobs to adjust the effect settings. The function of each knob will depend on the type of effect, as shown below.

	C1 knob	C2 knob	C3 knob
FILTER	Rate (modulation speed)*	Cutoff frequency	Resonance
ISOLATOR	Low gain	Middle gain	High gain
PHASER	Rate (modulation speed)*	Modulation depth	Resonance
SLICER	Rate (interval of cutting)*	Time to cut	Pan

Cutoff frequency: specifies the frequency at which the filter begins to be applied

Resonance: emphasizes the frequency region near the cutoff frequency

- * If you select the *F-1*, *F-2*, *P-1*, *P-2*, or *S-1* effect types (p. 44), it will not be possible to adjust the rate of the filter, phaser, or slicer.
- * The adjustments you make here are temporary. If you want to keep the new settings, you must Store them (p. 48).
- * For some settings, you can synchronize the rate of the filter, phaser, or slicer to the standard tempo. For details, refer to the table on the next page.

MEMO

Depending on the pattern you select, the indicator of the [LEAD], [BASS], or [RHYTHM] button will blink, and the [LOOP CTRL] button's indicator may light (Loop Control: On). This indicates that the selected pattern includes Loop Control settings (p. 53).

HINT

If you switch to a different effect pattern while the current effect pattern is still playing, playback will change to the newly selected effect pattern at the beginning of the next measure. However, the tempo of the previous effect pattern will be maintained.

HINT

The knob position may not match the actual value of the setting. In this case, turn the knob slightly, and then make the desired setting.

HINT

If you want to view the setting of a knob in the display while you adjust it, hold down the [SHIFT] button while you turn that knob.

HINT

If you want to check the setting of a knob in the display, hold down the [SHIFT] button and press the [DISPLAY] button. When you do this, the value of each knob will be displayed in the order of C1, C2, and C3.

Changing the effect type

Each effect provides several variations, which allow it to be controlled by the step sequencer or by external synchronization. These are called **effect types**. You can select the effect type that is most suitable for your performance situation.

	Effect type	Parameters that can be controlled	Smoothing	Synchroni- zation
Filter	<i>F-1</i>	Cutoff frequency	On	—
	<i>F-2</i>	Cutoff frequency	Off	—
	<i>F-3</i>	Resonance	On	○
	<i>F-4</i>	Resonance	Off	○
	<i>F-5</i>	—	—	○
	<i>F-6</i>	Resonance	On	—
	<i>F-7</i>	Resonance	Off	—
	<i>F-8</i>	—	—	—
Isolator	<i>I-1</i>	Low gain	On	—
	<i>I-2</i>	Low gain	Off	—
	<i>I-3</i>	Middle gain	On	—
	<i>I-4</i>	Middle gain	Off	—
	<i>I-5</i>	High gain	On	—
	<i>I-6</i>	High gain	Off	—
	<i>I-7</i>	—	—	—
Phaser	<i>P-1</i>	Modulation depth	On	—
	<i>P-2</i>	Modulation depth	Off	—
	<i>P-3</i>	Resonance	On	○
	<i>P-4</i>	Resonance	Off	○
	<i>P-5</i>	—	—	○
	<i>P-6</i>	Resonance	On	—
	<i>P-7</i>	Resonance	Off	—
	<i>P-8</i>	—	—	—
Slicer	<i>S-1</i>	Slice level	Off	—
	<i>S-2</i>	Pan	On	○
	<i>S-3</i>	Pan	Off	○
	<i>S-4</i>	—	—	○
	<i>S-5</i>	Pan	On	—
	<i>S-6</i>	Pan	Off	—
	<i>S-7</i>	—	—	—

Smoothing: When using the step sequencer to control the effect (p. 45), this creates smooth changes between each step.

Synchronization: The rate of the filter, phaser, or slicer will be synchronized to the standard tempo. Use the C1 knob to choose the note value for synchronization (16th note, 8th note, quarter note, half note, whole note, whole note x2, whole note x4).



If you want only Pan to change for S-5, S-6, or S-7, turn the C1 knob all the way to the left. If you want only resonance to change for F-6, F-7, or F-8, turn the C1 knob all the way to the left.

1

Select an effect pattern (p. 42).

2

Press the [DISPLAY] button enough times to get the TONE/TYPE indicator to light.

The display will show the effect type that is specified for the currently selected effect pattern.

3

Use the [INC] and [DEC] buttons to change the effect type.

* Changes you make are temporary. If you want to keep the new settings, you must save them (p. 48).

Creating consecutive changes in an effect (Effect Control)

You can use the step sequencer in conjunction with each effect to create consecutive changes in the effect settings. This is called **effect control**.

One measure is divided into 16 (or 12) steps, and you can input a value for each step to specify how the effect will change.

For example, you can use effect control to vary the cutoff frequency of the filter so that the filter will open and close in stepwise fashion.

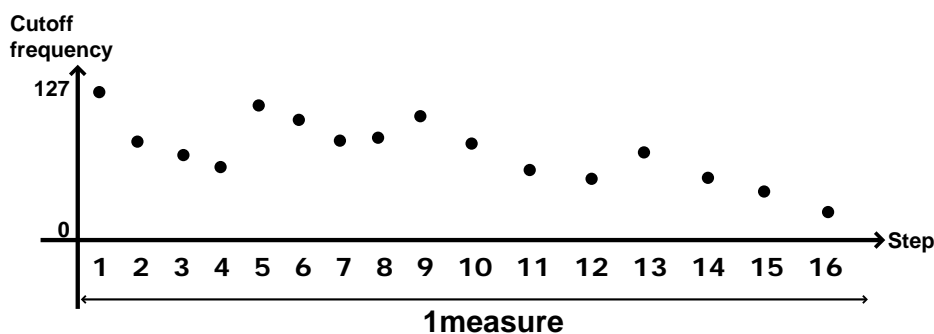

Since the effect control speed will follow the standard tempo, you can use it in conjunction with a variety of performances.

* If you are using loop control to play back a loop, it is not possible to use effect control.

What you need to do to use Effect Control

- (1) Select an effect type (p. 44)
- (2) Make effect control settings (p. 46)
- (3) Specify the speed of change (p. 57)



For the effect parameters that will be controlled by this feature, refer to the “Parameters that can be controlled” column of the effect type table (p. 44).

Using effect control to perform

When you play back an effect pattern for which Effect Control is specified, the effect will change consecutively.

1

Select an effect pattern for which effect control has been specified (p. 42).

2

As necessary, adjust the tempo at which the effect setting will change (p. 57).

3

Press the [▶](PLAY) button to begin playing the effect pattern. If you are applying the effect to the external input, start playing the external input as well.

If a loop has been recorded in the looper, the loop will begin playing at the same time.

4

To stop playback, press the [■](STOP) button.

Making effect control settings

1

Select an effect pattern (p. 42).

2

As necessary, change the effect settings or effect type.

** Do not select an effect type that does not use effect control (F-8, I-7, P-5, P-8, S-4, or S-7). Effect control settings cannot be made if you select one of these effect types.*

3

Press the [SEQ REC] button.

This puts you in Step Edit mode, where you can make effect control settings.

4

Press the [SETUP] button.

Now you are ready to make effect control settings.

- 5** Use the [INC] and [DEC] buttons to specify the length for effect control (1 or 2 measures).
The display will indicate the effect control length.
- 6** Press the [SCALE] button to specify the step unit and number of steps.
16th notes x16 steps: indicator dark
8th note triplets x12 steps: indicator lit
- 7** Press the [EXIT] button.
You will return to Step Edit mode.
- 8** Press a step [1]–[16] button to select the step whose value you will input.
If you want to input the same value for several steps, hold down one of the step buttons and then press the button(s) for the other step(s).
- 9** Turn the C3 knob to input the value.
- 10** Repeat steps 8 and 9 to make effect control settings.
- 11** When you are finished making effect control settings, press the [EXIT] or [■] button.

* *The effect control settings you make are temporary. If you want to keep your effect control settings, you must save them (p. 48).*

MEMO

If the effect control length is set to 2 measures, you can change the measure position by pressing the [SCALE] button to make the display show the measure number, and then pressing the [INC] or [DEC] button. To check the current measure location, press and hold the [SCALE] button. The previous display will reappear when you release the button.

Saving your effect settings

If you want to save your effect settings or effect control settings, you must save the effect pattern.

- * *All your changes will be lost if you select another effect pattern or turn off the power before saving.*
- * *The Save operation cannot be performed while a effect pattern is playing.*

The following data will be saved

- Effect type
- Parameter settings (the settings of the C1–C3 knobs)
- Effect control settings
- Loop control settings (p. 56)
(If loop control settings are not included)

1

Press the [WRITE] button.

The effect pattern number in the display will blink.

2

Use the [INC] and [DEC] buttons to select the save-destination effect pattern number.

Select U01–U20 if you want to save the settings in internal memory. Select C01–C50 if you want to save the settings on a memory card.

- * *Since the data you save will overwrite any previous data at that location, the previous data will be lost. Make sure that the selected number does not contain a pattern you want to keep.*

3

Press the [WRITE] button to execute.

The display will indicate “Sur”, asking you to confirm the operation.

4

Press the [WRITE] button to save the settings.

While a pattern is being saved, the display will show “bsy”. When the data has been saved, you will return to the screen in which you were prior to beginning the Save process.

- * *Should you decide that you don't want to carry out the save, press the [EXIT] button.*



You can save 20 patterns (total for LEAD, BASS, RHYTHM, and EFFECTS groups) in internal memory.

Changing the way in which a loop plays (Loop Control)

What is Loop Control?

You can use the step sequencer in conjunction with a loop to change the way in which the loop plays back. This is called **loop control**.

You can use loop control to play a loop in three ways.

- Play the loop while changing its pitch (**Pitch**)
- Play specified parts in succession (**Trigger**)
- Divide the loop, and play it back in reassembled form (**Divide times 16**)

Since the loop control speed will follow the standard tempo, you can use it in a variety of performance situations.

Normal playback and Loop Control

Normally, a loop will play back repeatedly in synchronization with the standard tempo. However, when you use Loop Control, the sound will play back in a different way, producing a different result.

Pitch

The loop will play back at a different pitch in each step. This lets you play the loop at specific pitches.

* *Pitch can be used only for part 1.*

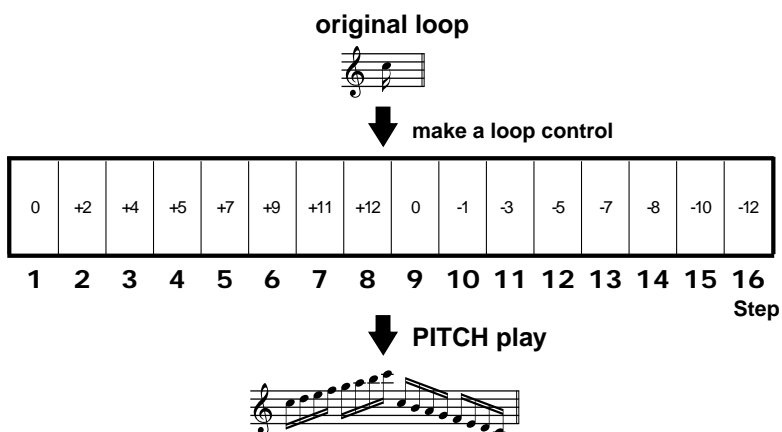

* *When you change the pitch, the playback speed of the loop itself will change correspondingly, similarly to how the pitch rises when a tape recorder is speeded up, and falls when it is slowed down. For this reason, silent portions may occur if you raise the pitch, speeding up the loop playback. Likewise, the loop may not play all the way to the end if you lower the pitch.*

Changing the way in which a loop plays (Loop Control)

Trigger

Normally when you play the loop, the four parts will play back together. By using Trigger playback, you can play the four parts separately. For each step, you can specify which part will play. This lets you create performances similar to those produced by striking the pads of a sampler.

Part 1	Part 2	Part 3	Part 4	Part 1	Part 2	Part 3	Part 4	Part 2	Part 4	Part 3	Part 4	Part 1	Part 2	Part 1	Part 2
1	2	3	4	5	6	7	8	9	10	11	12	13	14	15	16
															Step

* It will not be possible to capture if you use all pads for Trigger playback.

Divide times 16

The loop will be divided into 16 or 12 equal sections along the time axis, and the section will be assigned to each step for playback. For example, you can divide the loop of a drum performance, so that the performance is approximately divided into individual rhythm instruments, such as bass drum, snare drum, and hi-hat. Then you can use this to create a new performance in which only the specific beats you select are heard.

- * Divide times 16 will affect only part 1.
- * The loop will be divided into 16 or 12 sections along the time axis, but the loop itself will not be divided.



It is not possible to correct inaccuracies in the performance.

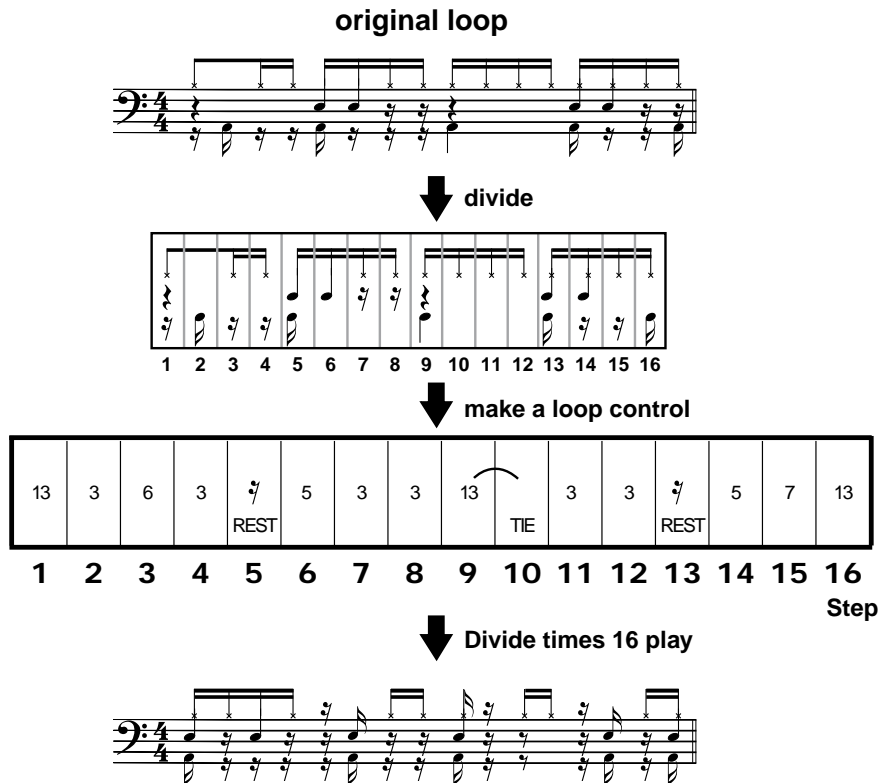

Using loop control for realtime performance

Realtime pitch performance

You can use the step [1]–[16] buttons to play part 1 at different pitches.

* There will be no sound if you exceed a range of one octave higher or lower than the original pitch of part 1.

1

Load the loop that you want to play into part 1 (p. 59).

2

Press the [LOOP CTRL] button so its indicator lights.

Loop control will be turned on.

3

Press the [DISPLAY] button so the TONE/TYPE indicator lights.

4

Press the [INC] or [DEC] button to get the “Pch” display.

5

Perform the sound by pressing the step [1]–[16] button corresponding to the desired pitch.

While you press a step [1]–[16] button, part 1 will play at the pitch corresponding to the button you pressed. However, it will not play repeatedly.

The step [1]–[16] buttons correspond to different pitches as follows.

		1	2	3	4	5	6	7	8	9	10	11	12	13	14	15	16	
Octave shift	-2	x	x	x	x	x	x	x	x	x	x	x	x	x	x	x	x	
	-1	x	-12	-11	-10	-9	-8	-7	-6	-5	-4	-3	-2	-1	0	1	2	
	0	-1	0	1	2	3	4	5	6	7	8	9	10	11	12	x	x	
	1	11	12	x	x	x	x	x	x	x	x	x	x	x	x	x	x	x
	2	x	x	x	x	x	x	x	x	x	x	x	x	x	x	x	x	x

6

When you are finished with realtime pitch performance, press the [LOOP CTRL] button so the indicator goes out.

Changing the way in which a loop plays (Loop Control)

Realtime performance using Trigger

You can play parts 1–4 by pressing the step [1]–[4] buttons. This is convenient for live performance.

1

Load the loop that you want to play into part 1–4 (p. 59).

2

Press the [LOOP CTRL] button so its indicator lights.

Loop control will be turned on.

3

Press the [DISPLAY] button so the TONE/TYPE indicator lights.

4

Press the [INC] or [DEC] button to get the “*tr 9*” display.

5

Press the step [1]–[4] button for the part you want to play.

While you hold down the step [1]–[4] button, the corresponding part will sound. However, it will not play back repeatedly.

6

When you are finished with trigger performance, press the [LOOP CTRL] button so the indicator goes out.

Realtime performance using Divide times 16

You can play each divided section of the sound by pressing the step [1]–[16] buttons. This lets you recreate a loop as a new performance.

1

Load the loop that you want to play into part 1 (p. 59).

2

Press the [LOOP CTRL] button so its indicator lights.

Loop control will be turned on.

3

Press the [DISPLAY] button so the TONE/TYPE indicator lights.

4

Press the [INC] or [DEC] button until “*dPd*” appears in the display.

The loop will be divided into 16 or 12 sections.

MEMO

If you want to divide the loop into 12 sections, press the [SETUP] button, then press the [SCALE] button so its indicator lights.

5 Press the step [1]–[16] button for the section that you want to play.

6 When you are finished with Divide times 16 performance, press the [LOOP CTRL] button so the indicator goes out.

Playing back a loop with Loop Control

Loop Control is included within the pattern or effect pattern. You can play back in a different way than the original loop, simply by selecting a pattern or effect pattern for which Loop Control is specified, and pressing the [▶] (PLAY) button.

- * *The contents (MIDI messages) of Loop Control are not transmitted from MIDI IN to an external MIDI device.*
- * *If you use Loop Control while applying an effect, it will not be possible to use Effect Control.*
- * *You cannot play back a pattern while using Loop Control.*

1 Make sure that the loop you want to play is recorded in the Audio Looper.

- * *If a loop has not been loaded into the Audio Looper, there will be no sound even if you press the [▶] (PLAY) button.*

2 Select a pattern or effect pattern that uses Loop Control.

When you select a pattern or effect pattern for which Loop Control has been specified, Loop Control will automatically be turned on.

First, let's try this out using a preset pattern.

Type	Preset pattern		
	LEAD	BASS	RHYTHM
Pitch playback	P38	P58	P98
Trigger playback	P39	P59	P99
Divide times 16 playback	P40	P60	P00

3 As necessary, specify the tempo at which Loop Control will change (p. 57).

4 Press the [▶] (PLAY) button.

The loop will play back according to the Loop Control setting.

5 To stop playback, press the [■] (STOP) button.

MEMO

When loop control is turned on, the pattern and effect control settings will be ignored. This means that if you play back a pattern in which loop control is turned on, there will be no sound. Also, effect control cannot be used for an effect pattern in which loop control is turned on. If you want to use a pattern or effect control, you must turn loop control on.

Making loop control settings

1 Select the pattern or effect pattern for which you want to store loop control settings.

If you want to edit an existing loop control setting, select the pattern/effect pattern that includes it.

2 Press the [LOOP CTRL] button so its indicator lights.
Loop control will be turned on.

3 Press the [DISPLAY] button enough times to get the TONE/
TYPE indicator to light.

4 Use the [INC] and [DEC] buttons to select the loop control
type.

Pch : Pitch

trg : Trigger

dPd : Divide times 16

5 Press the [SEQ REC] button.
You will enter a mode in which you can make loop control settings (Step Edit).

6 Press the [SETUP] button.
This lets you make preparatory settings for loop control.

7 Use the [INC] and [DEC] buttons to specify the loop control
length (1 or 2 measures).
The display will show the loop control length.

8 Press the [SCALE] button to select the step unit and number of
steps.

16th notes x 16 steps: indicator dark

8th note triplets x 12 steps: indicator lit

MEMO

If loop control settings have already been made, you can press the [REST] button in loop control settings to erase the values of all steps.

Changing the way in which a loop plays (Loop Control)

9

Press the [EXIT] button.

You will exit preparatory settings for loop control.

10

Press a step [1]–[16] button to specify the step for which you will input a value.

If you want to input the same value for more than one step, hold down the button for one step and press the button(s) for the other step(s).

** It is not possible to input more than one value at each step. If you select a step for which a value has already been input, the existing data will be replaced by the new data.*

11

Turn the C3 knob to input the desired value.

Type	Value	Explanation
Pitch	-12–12, t iE (TIE), r 5t (REST)	Raise or lower the pitch by up to 1 octave in semitone steps relative to the original pitch of the loop. A setting of “1” raises the pitch by a semitone, and “-1” lowers the pitch by a semitone.
Trigger	1–4, — (don’t play), r 5t	Specify the part that will be played. To stop playback mid-way through, use r 5t .
Divide times 16	1–16 (12), r 5t (REST)	Specify which of the 16 or 12 sections will be played. The number of divisions is specified in step 7.

12

Repeat steps 10 and 11 to make loop control settings.

13

When you are finished making loop control settings, press the [EXIT] or [■] button.

** The settings you make are temporary. If you want to keep your new settings, you must save them (p. 56).*

MEMO

If the loop control length is set to 2 measures, you can change the measure location by holding down the [SCALE] button to get the display to show the measure number, and pressing the [INC] or [DEC] button. To check the current measure location, press and hold the [SCALE] button. The previous display will reappear when you release the button.

Saving your loop control settings

If you want to preserve the loop control settings, save the pattern/effect pattern that contains them.

- * *The settings you make will be lost if you select another loop control pattern or turn off the power before saving.*
- * *The Save operation cannot be performed while a pattern or effect pattern is playing.*

1

Press the [WRITE] button.

The pattern/effect pattern number in the display will blink.

2

Use the [INC] and [DEC] buttons to select the save-destination pattern/effect pattern number.

Select U01–U20 to save your data in internal memory, or C01–C50 to save your data on a memory card.

- * *Since the data you save will overwrite any previous data at that location, the previous data will be lost. Make sure that the selected number does not contain a pattern you want to keep.*

3

Press the [WRITE] button to execute.

The display will indicate “Sur”, asking you to confirm the operation.

4

Press the [WRITE] button to write.

While a pattern/effect pattern is being saved, the display will show “bsy”. When the data has been saved, you will return to the screen in which you were prior to beginning the Save process.

If you decide not to save the pattern/effect pattern, press the [EXIT] button.

MEMO

You can save 20 patterns (total for LEAD, BASS, RHYTHM, and EFFECTS groups) in internal memory.

About the tempo

The MC-09 has a single tempo setting that governs the playback. This is called the **standard tempo**. Although each pattern also has its own tempo, this is separate from the standard tempo. When you select a pattern, its tempo will be loaded and will become the standard tempo. The standard tempo can be adjusted in a range of ♩ = 40 through ♩ = 240.

Pattern, effect control, and loop control will play back according to the standard tempo. In addition, effect parameters such as phaser rate and LFO rate will also synchronize to the standard tempo while a pattern, effect control, or loop control is playing.

You can also make pattern, effect control, and loop control play in synchronization with the tempo of an external MIDI device, regardless of the standard tempo (p. 64).

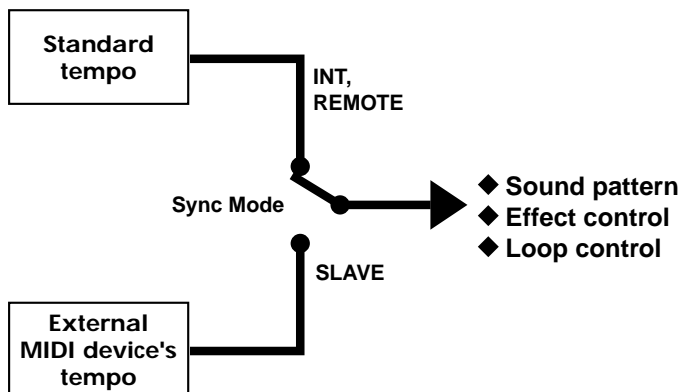

Checking the standard tempo

1. Press the [DISPLAY] button so the BPM indicator lights.

The value shown in the display is the current standard tempo.

* If the MC-09 is set to synchronize to an external MIDI device (i.e., when Sync Mode = Slave), this will indicate " - - - ".

Setting the tempo manually

1. Press the [DISPLAY] button so the BPM indicator lights.
2. Use the [INC] and [DEC] buttons to set the tempo.

Setting the tempo with the [TAP] button

You can set the tempo by pressing the [TAP] button at the desired timing.

1. Press the [DISPLAY] button so the BPM indicator lights.
2. Press the [TAP] button three times or more at the desired quarter-note interval.

When you press the button three times or more, the tempo will be calculated automatically, and will appear in the display.

What is BPM?

BPM stands for Beats Per Minute, and indicates the number of quarter note beats that occur in one minute.

Using a memory card

Memory cards usable with the MC-09

The MC-09 can use commercially available SmartMedia memory cards. However, a memory card is not included. You can purchase a memory card at a nearby computer shop or digital camera dealer. When you purchase a memory card, make sure that it meets the following conditions.

- Power supply voltage: 3.3 V
- Capacity: 2 MB–128 MB
- * *The MC-09 cannot use SmartMedia of types other than the above.*
- * *If you use 2 MB Smart Media, it may not be possible to save all data.*

Cautions when using a memory card

- * *The power of the MC-09 must be off when you insert or remove a memory card. Inserting or removing a memory card when the power is on will damage the memory card as well as the data in the MC-09.*
- * *Make sure that the memory card is oriented correctly, and push it all the way into the slot.*

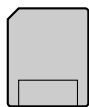
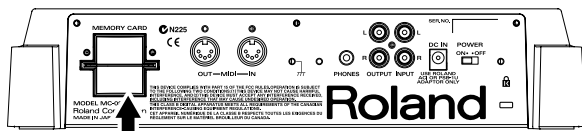

The surface without gold contacts must face upward.

- * *Never turn on the power when a memory card is inserted part-way into the slot. Doing so will damage the data in internal memory.*
- * *Never turn off the power while **b54** appears in the display. Doing so will damage the data in the memory card and internal memory.*

Formatting a memory card

This operation prepares the memory card for use on the MC-09. You will need to format a newly purchased memory card before using it for the first time, or before a memory card used with another device can be used on the MC-09.

- * *When you format a memory card, the entire contents of the card will be erased.*

1. Press the [SETUP] button.
2. Press the [INC] or [DEC] button until the display indicates “**Fnt**”.
3. Press the [ENTER] button.

The display will show “**Sur**”.

4. To format the card, press the [WRITE] button.

While the card is being formatted, “**b54**” will appear in the display. When formatting is finished, you’re returned to where you were in step 2.

- * *If you decide not to format the card, press the [SETUP] button or the [EXIT] button.*
5. Press the [SETUP] button.

Saving a loop to a memory card

The loops recorded in the audio looper can be saved on a memory card. Here we will explain how to save individual loops of the specified part.

1. Press the [SETUP] button.
2. Press the [INC] or [DEC] button until the display indicates “*LP5*”.

3. Press the [ENTER] button.

The display will show the save-destination file number (L01–L50).

4. Press one of the audio looper [SEL] buttons to specify the part that you want to save.
5. Use the [INC] and [DEC] buttons to select the save-destination file number.
 - * Should you decide that you don't want to carry out the save, press the [SETUP] button or the [EXIT] button.
6. Press the [WRITE] button to begin saving the data.

While the data is being saved, “*654*” will appear in the display. When saving is complete, you're returned to where you were in step 2.

* If the save-destination file number already exists on the memory card, the display will indicate “*Sur*”. If you want to save the new data by overwriting the old, press the [ENTER] button. If you want to save the data with a different file number, press the [EXIT] button and repeat the procedure from step 2.

* It may take up to three minutes for saving one loop.

7. Press the [SETUP] button.



When you save a loop to a memory card, it is saved in the MC-09's own original format. This means that loops you create on the MC-09 cannot be loaded or used by a personal computer or hard disk recorder. If you want to use an MC-09 loop on a different device, you will have to record the loop onto that device as an audio signal.

Loading a loop

Here's how to load a loop from a memory card into the audio looper.

1. Press the [SETUP] button.
2. Press the [INC] or [DEC] button until the display indicates “*LP.L*”.
3. Press the [ENTER] button.

The display will show one of the file numbers (L01–L50) that have been saved on the memory card.

4. Press one of the audio looper [SEL] buttons to select the part into which the data will be loaded.
5. Use the [INC] and [DEC] buttons to select the load-source file number.
 - * If you decide you don't want to load a file, press the [SETUP] button or the [EXIT] button.
6. Press the [WRITE] button to begin loading.

The display will show “*654*” while the data is being loaded. When loading is finished, you're returned to where you were in step 2.

* If a loop already exists in the load-destination part, the display will indicate “*Sur*”. If it is ok to overwrite this existing data when you load, press the [ENTER] button. If you decide to load the data into a different part, press the [EXIT] button and repeat the procedure from step 2.

* It may take up to three minutes for loading one loop.

7. Press the [SETUP] button.

Deleting a saved loop from memory card

Here's how to delete a saved loop from memory card.

1. Press the [SETUP] button.
2. Press the [INC] or [DEC] button until the display indicates “*LP.d*”.

3. Press the [ENTER] button.

The display will show one of the file numbers (L01–L50) that have been saved on the memory card.

4. Use the [INC] and [DEC] buttons to select the number of the file that you want to delete.
5. Press the [WRITE] button.

The display will indicate “*Sur*”, asking you to confirm the operation.

* If you decide not to delete the loop, press the [SETUP] button or the [EXIT] button.

6. Press the [ENTER] button to delete the loop.

While the loop is being deleted, the display will show “*654*”. When the loop has been deleted, you're returned to where you were in step 2.

7. Press the [SETUP] button.

Saving all settings of the MC-09 to a memory card

The following settings stored in the audio looper will be saved together on the memory card.

- All loops and user patterns
- Process patch
- System settings
- The settings of the currently selected pattern/effect pattern



For details on system settings, refer to “Parameter list” (p. 71).

1. Press the [SETUP] button.
2. Press the [INC] or [DEC] button until the display indicates “*AL5*”.

3. Press the [ENTER] button.

The display will show the save-destination file number (A01–A50).

4. Use the [INC] and [DEC] buttons to select the desired save-destination file number.

* Should you decide that you don't want to carry out the save, press the [SETUP] button or the [EXIT] button.

5. Press the [WRITE] button to begin saving.

While the settings are being saved, the display will show “*b5Y*”. Once the save is complete, you're returned to where you were in step 2.

* If the save-destination file number already exists on the memory card, the display will indicate “*Sur*”. If you want to save the new data by overwriting the old, press the [ENTER] button. If you want to save the data with a different file number, press the [EXIT] button and repeat the procedure from step 2.

* It may take up to three minutes for saving one loop.

6. Press the [SETUP] button.



When loops are saved to a memory card, they are saved in the MC-09's own original format.

Loading MC-09 settings

Here's how MC-09 settings saved on a memory card can be loaded back into the MC-09.

1. Press the [SETUP] button.
2. Press the [INC] or [DEC] button until the display indicates “*ALL*”.

3. Press the [ENTER] button.

The display will show one of the file numbers (A01–A50) that have been saved in the memory card.

4. Use the [INC] and [DEC] buttons to select the file number that you want to load.

* If you decide not to load a file, press the [SETUP] button or the [EXIT] button.

5. Press the [WRITE] button.

The display will indicate “*Sur*”, asking you to confirm the operation.

6. Press the [ENTER] button to load MC-09 settings.

While the settings are being loaded, the display will show “*b5Y*”. Once the data's been loaded, you're returned to where you were in step 2.

* It may take up to three minutes for loading one loop.

7. Press the [SETUP] button.

Deleting saved MC-09 settings from a memory card

Here's how to delete MC-09 settings that were saved on memory card.

1. Press the [SETUP] button.

2. Press the [INC] or [DEC] button until the display indicates “*ALd*”.

3. Press the [ENTER] button.

The display will show one of the file numbers (A01–A50) that have been saved on the memory card.

4. Use the [INC] and [DEC] buttons to select the number of the file that you want to delete.

5. Press the [WRITE] button.

The display will indicate “*Sur*”, asking you to confirm the operation.

* If you want to cancel the deletion, press the [SETUP] button or the [EXIT] button.

6. Press the [ENTER] button to delete MC-09 settings.

While the MC-09 settings are being deleted, “*b5Y*” will appear in the display. When the deletion is complete, you're returned to where you were in step 2.

7. Press the [SETUP] button.

Connecting external MIDI devices

By using MIDI cables to connect devices that have MIDI connectors, you can synchronize two or more MIDI devices or control them simultaneously.

* For an explanation of MIDI-related parameters, refer to “Parameter functions” (p. 71).

MIDI signal flow

The following diagram shows the signal flow of MIDI messages within the MC-09

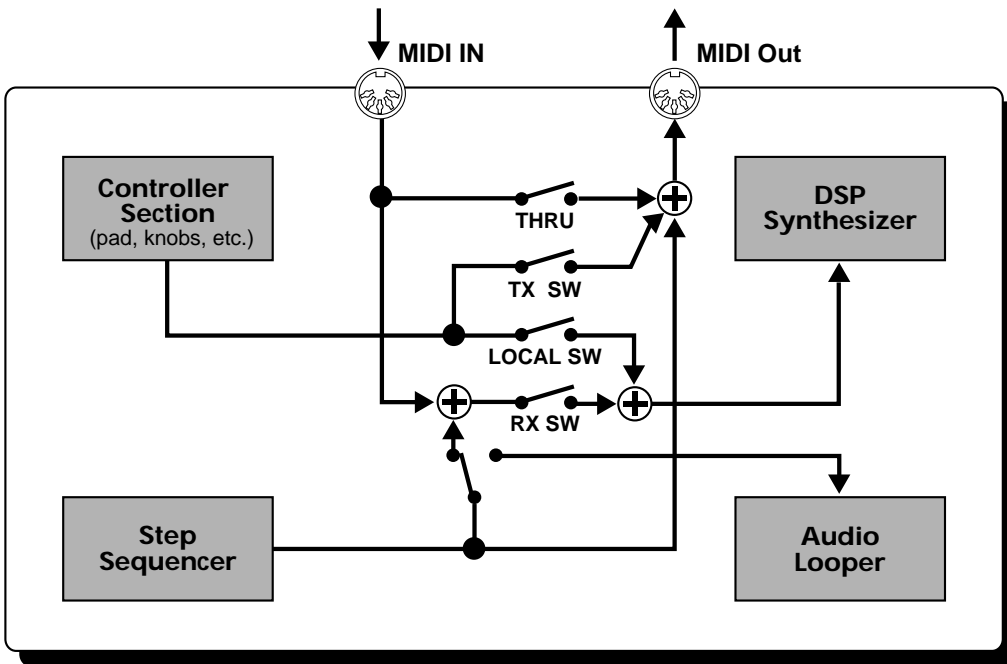

Setting the MIDI channel

On the MC-09, you can select one of the sixteen MIDI channels. The selected channel will be used for MIDI reception and transmission.

1. Press the [SETUP] button.
2. Press the [INC] or [DEC] button until the display indicates “*NC h*” (MIDI Channel).

This lets you set the MIDI channel.

3. Press the [ENTER] button.
The display will show the MIDI channel.
4. Use the [INC] and [DEC] buttons to change the MIDI channel.
5. Press the [SETUP] button to complete the setting.

Using the MC-09 as the master

The device that transmits MIDI messages is called the **master**, and the device that receives the messages is called the **slave**. Here’s how you can use the MC-09 as the master and an external MIDI device as the slave.

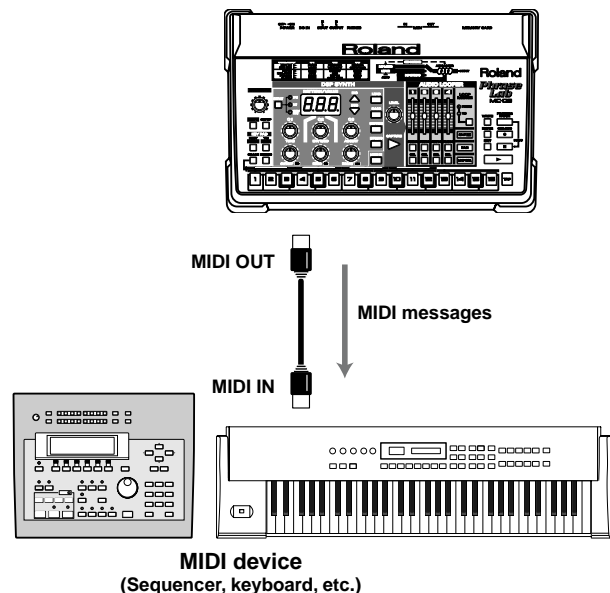

Controlling an external MIDI device

You can operate the MC-09's knobs and keyboard pads to switch sounds on an external MIDI device or modify its settings.

1. Set the MC-09 and the external MIDI device to the same MIDI channel (p. 61).
2. Press the [SETUP] button.
3. Press the [INC] or [DEC] button until the display indicates " *TPC* "(Tx. Program Change).
4. Press the [ENTER] button.
5. Press the [INC] or [DEC] button until the display indicates " *On* "(ON).

With this setting, when you switch pattern, effect pattern, or loop control pattern on the MC-09, the external MIDI device will also switch sounds.

6. Press the [SETUP] button to complete the setting.
7. Make settings on your external MIDI device.

Make settings on your external MIDI device so that it will receive MIDI messages. For details, refer to the owner's manual for your device.

8. Play the MC-09, or operate its knobs and keyboard pads.

The external MIDI device will play sounds or switch sound settings accordingly.

Synchronizing an external MIDI sequencer

Here's how you can make an external MIDI sequencer play back in synchronization with the tempo of the MC-09.



For details on setting the tempo of the MC-09, refer to "About tempo" (p. 57).

1. Set the MC-09 and the external MIDI device to the same MIDI channel (p. 61).
2. Press the [SETUP] button.
3. Press the [INC] or [DEC] button until the display indicates " *SYN* "(Sync Mode).
4. Press the [ENTER] button.
5. Make sure that the display shows " *int* "(INTERNAL).

With this setting, the external MIDI sequencer will synchronize to the tempo of the MC-09.

6. Press the [EXIT] button.
7. Press the [INC] or [DEC] button until the display indicates " *SYO* (Sync Out)."
8. Press the [ENTER] button.
9. Press the [INC] or [DEC] button until the display indicates " *On* "(ON).

With this setting, the MC-09 will transmit tempo messages to the external MIDI sequencer.

10. Press the [SETUP] button to complete the setting.
11. Make settings on your external MIDI sequencer.

Set your external MIDI sequencer to synchronize to an external MIDI clock. For details, refer to the owner's manual for your sequencer.

12. Press the MC-09's [▶] (PLAY) button.

Your external MIDI sequencer will also begin playing.

13. To stop playback, press the [■] (STOP) button.

Using the MC-09 as the slave

The device that transmits MIDI messages is called the **master**, and the device that receives the messages is called the **slave**. Here's how you can use the MC-09 as the slave and an external MIDI device as the master.

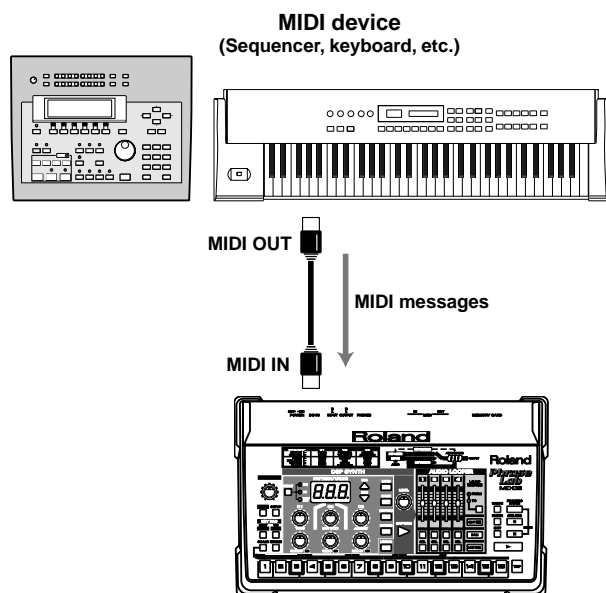

* When using the MC-09 as the slave, do not transmit unnecessary MIDI messages from the external MIDI device on the MIDI channel that the MC-09 is receiving. Unnecessary MIDI messages from an external MIDI device may change the settings of the MC-09.

Playing the MC-09 from an external MIDI device

When you play an external MIDI sequencer or keyboard, the MC-09's DSP synthesizer (the pattern tone or rhythm set) will sound.

Since the keyboard pads have a range of slightly more than one octave, your playing on them will be limited. However, if you use an external MIDI keyboard, you will be able to play the MC-09's sounds with greater range.

1. Select a pattern from the LEAD, BASS, or RHYTHM group.
2. Set the same MIDI channel for the MC-09 and your external MIDI device (p. 61).
3. Make settings on your external MIDI device.
Make settings on your external MIDI device so that it will transmit MIDI messages. For details, refer to the owner's manual of your device.
4. Play your external MIDI device.

The MC-09's DSP synthesizer will sound accordingly.

Controlling the MC-09 from an external MIDI device

By transmitting program change messages from an external MIDI device, you can switch the MC-09's pattern, effect pattern, or loop control pattern. You can also transmit control change messages to modify the MC-09's sound settings.

1. Set the MC-09 and your MIDI device to the same MIDI channel (p. 61).
2. Press the [SETUP] button.
3. Use the [INC] and [DEC] buttons to select one of the following parameters.

r.PC (Rx.Program Change)

Program changes can be transmitted from an external MIDI device to switch the MC-09's sound, effect, or loop control patterns.

r.CC (Rx.Control Change)

Control changes can be transmitted from an external MIDI device to change settings such as cutoff frequency or resonance.

r.Pb (Rx.Pitch Bend)

Pitch bend messages can be transmitted from an external MIDI device to change the pitch.

r.E = (Rx.SysEX)

System exclusive messages can be transmitted from an external MIDI device to change various settings.

SYN (Sync Mode)

Start/Stop messages can be transmitted from an external MIDI device to play/stop the MC-09's pattern, effect control, or loop control.

4. Press the [ENTER] button to confirm your choice of parameter.
 5. Press the [INC] or [DEC] button until the display indicates "On" (ON).
- If you selected *SYN* (Sync Mode) in step 3, make the display show "*r.NE*" (REMOTE).
6. If you want to make reception settings for another parameter, press the [EXIT] button, and then repeat steps 3-5.
 7. When you are finished making settings, press the [SETUP] button.

8. Make settings on your external MIDI device.
Set your external MIDI device so that it will transmit the appropriate type of MIDI message. For details, refer to the owner's manual for your device.
9. Transmit the appropriate type of MIDI message from your external MIDI device to control the MC-09.

Synchronizing the MC-09 to an external MIDI sequencer

The pattern, effect control, or loop control playback can be synchronized to the tempo of an external MIDI sequencer.

* *If the MC-09 is synchronized to an external MIDI sequencer, loops may not play back correctly.*

1. Set the MC-09 and your external MIDI device to the same MIDI channel (p. 61).
2. Press the [SETUP] button.
3. Press the [INC] or [DEC] button until the display indicates "SYN" (Sync Mode).
4. Press the [ENTER] button.
5. Press the [INC] or [DEC] button until the display indicates "SLV" (SLAVE).

The MC-09 will synchronize to the tempo of the external MIDI sequencer.

6. Press the [SETUP] button to complete the setting.
7. Make settings on your external MIDI sequencer.

Set your external MIDI sequencer so that it will transmit MIDI clock messages. For details, refer to the owner's manual for your sequencer.

8. Start playback on your external MIDI sequencer. Pattern, effect control, or loop control playback will also begin on the MC-09.
9. When playback ends, stop your external MIDI sequencer.

Using the MC-09 with your computer

By using the MC-09 in conjunction with MIDI sequencer software on your computer, you can use the MC-09 as a synthesizer module or controller.

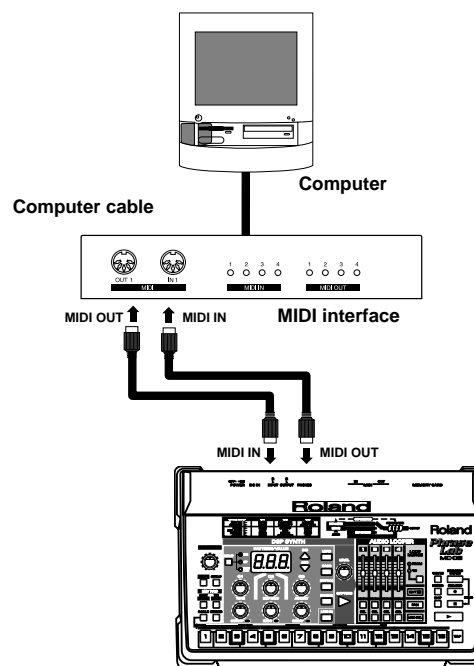

* *Use a MIDI interface that is compatible with your computer. For details on connecting your MIDI interface, refer to the owner's manual of the product you are using.*

1. Set the MC-09 and your MIDI sequencer software to the same MIDI channel (p. 61).
2. In your MIDI sequencer software, turn the thru function "ON."

Next, you will make settings to prevent MIDI messages from looping endlessly between the computer and the MC-09.

3. Press the [SETUP] button.
4. Press the [INC] or [DEC] button until the display indicates "thr" (Soft Thru).
5. Press the [ENTER] button.
6. Press the [INC] or [DEC] button until the display indicates "OFF" (OFF).
7. Press the [EXIT] button.
8. Press the [INC] or [DEC] button until the display indicates "LCL" (Local Switch).
9. Press the [ENTER] button.

10. Press the [INC] or [DEC] button until the display

indicates “OFF” (OFF).

With these settings, the MC-09 will receive MIDI messages from your computer, and the DSP synthesizer (pattern tone/rhythm set) will sound.

11. Press the [SETUP] button to complete the settings.

Saving the MC-09 settings to an external sequencer (Bulk Dump)

Data for the currently selected pattern, process patch or all saved settings, can be transmitted to an external MIDI device. This function is called **bulk dump**. You can create a backup of the MC-09's data by using bulk dump to record the data on an external MIDI sequencer. You can also use this function to replicate the current settings of one MC-09 (except for the Loop setting) on another MC-09.

Saving MC-09 data on an external MIDI sequencer

1. Use a MIDI cable to connect the MC-09's MIDI OUT to the MIDI IN of your external MIDI sequencer.
2. Press the [SETUP] button.
3. Press the [INC] or [DEC] button until the display indicates “dnp” (Bulk Dump).
4. Press the [ENTER] button.
5. Use the [INC] and [DEC] buttons to select the data that you want to save.

Pat: Settings for the currently selected pattern

Proc: Process patches

ALL: All patterns, process patches, and system settings

6. Press the [ENTER] button.

The display will blink “Sur” (Sure), asking you to confirm the operation.

If you decide to cancel, press the [EXIT] button.

7. Begin recording on your external MIDI sequencer.
8. Press the [ENTER] button to initiate the bulk dump.

While the data is being transmitted, the indication in the display will blink. When transmission is completed, the display will show **End**.

9. Stop recording on your external MIDI sequencer.
10. Press the [EXIT] button to complete the bulk dump.

Restoring MC-09 data from an external MIDI sequencer

The data that was saved by a bulk dump is referred to as **bulk data**. By loading this bulk data, you can reproduce the state in which the MC-09 was when it transmitted the bulk data.

1. Use a MIDI cable to connect the MC-09's MIDI IN to the MIDI OUT of the external MIDI sequencer.
2. Press the [SETUP] button.
3. Press the [INC] or [DEC] button until the display indicates “rcp” (Bulk Receive).
4. Press the [ENTER] button.

The MC-09 will wait to receive bulk data.

If you decide to cancel, press the [EXIT] button.

5. Play back your external MIDI sequencer to transmit the bulk data to the MC-09.

While the MC-09 is receiving bulk data, the display will blink.

When bulk data reception ends, the display will indicate

“BSY”. This display will continue for approximately 60 seconds.

* Never turn off the power while “BSY” appears in the display. Doing so will damage the data in the memory card and internal memory.

* You must transmit all of the bulk data.

6. Press the [EXIT] button to complete the operation, after the display indicates “rcp”.

How the MC-09 is organized

Audio signal flow

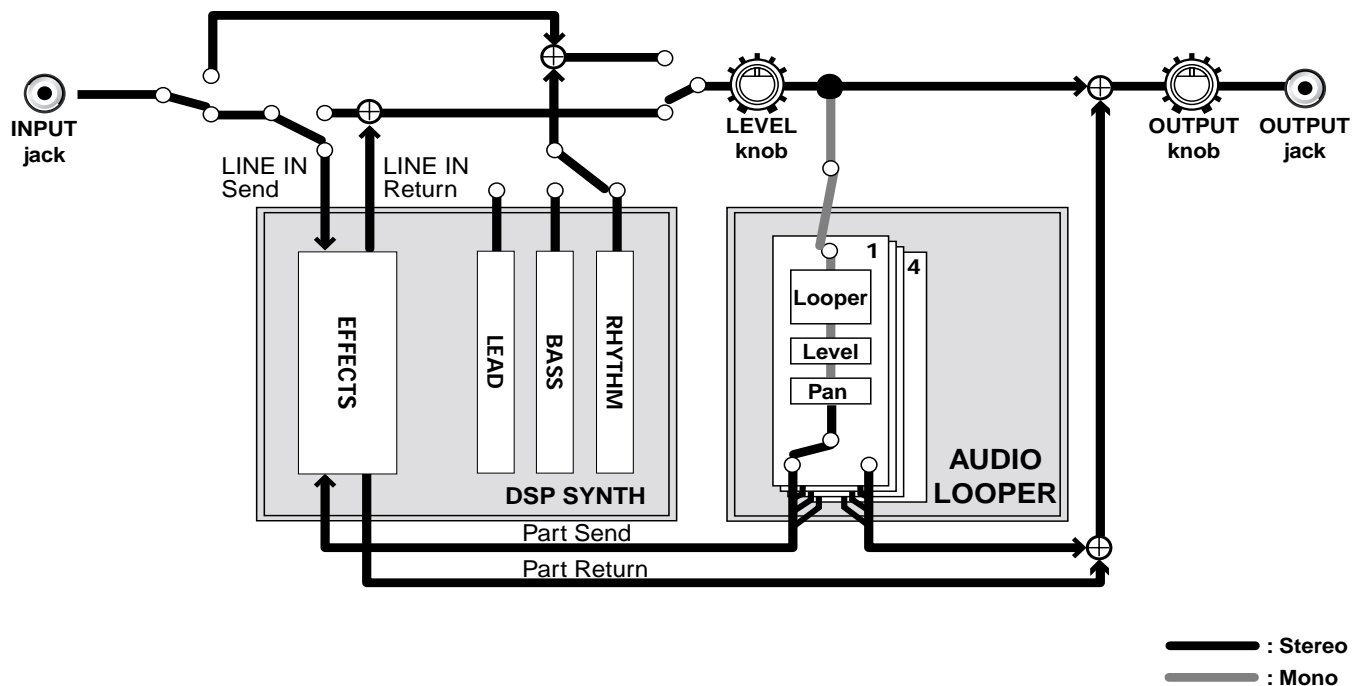

DSP synthesizer

This section produces the sound, and acts as an effects processor when processing the sound. It produces sound when it is played by the step sequencer or keyboard pads. It can also be played by an external MIDI device.

This section can also apply effects to an external audio source or a loop that you recorded in the audio looper. By using the step sequencer for effect control, you can modulate the effect cyclically.

Audio looper

This section records (captures) or processes the sound of a DSP synthesizer performance or an external audio source. By repeatedly playing back the recorded sounds, you can play loop phrases for up to four parts. In addition, this playback can be played simultaneously with the performance of the DSP synthesizer.

You can also apply effects to a loop or use the step sequencer in conjunction with loop control to play back the recorded phrases in even more diverse ways.

Step sequencer

This section plays the pattern phrases, effect control, and loop control data, and lets you make settings. It uses MIDI messages to control the DSP synthesizer and the audio looper.

What knobs do

Common condition

MODE		C1 knob	C2 knob	C3 knob	CUTOFF knob	RESO knob	DECAY knob	[INC]/[DEC] (DISPLAY=TONE/ TYPE)
LINE IN		—	—	—	—	—	—	—
LEAD	Overdrive/ Distortion	OSC tune *	Drive	Tone	Cutoff frequency	Resonance	Filter envelope decay time	Tone
	Phaser	Rate	Depth	Resonance				
	Slicer+ Ring modulator	Rate	Gate time	Ring frequency				
BASS		OSC tune *	Filter envelope depth	Accent	Cutoff frequency	Resonance	Filter envelope decay time	Tone
RHYTHM		—	—	—	Bass drum level	Snare drum level	Hi-hat level	Rhythm set
EFFECT	Filter	Rate	Cutoff frequency	Resonance	—	—	—	Effect type
	Isolator	Low gain	Middle gain	High gain				
	Phaser	Rate	Depth	Resonance				
	Slicer	Rate	Gate time	Pan				
LOOP CTRL		—	—	—	—	—	—	Loop control type

* To return to the standard value (0), hold down the [SHIFT] key and press the [KEYBOARD] button.

Recording condition

MODE		C1 knob	C2 knob	C3 knob	CUTOFF knob	RESO knob	DECAY knob	[INC]/[DEC] (DISPLAY=TONE/ TYPE)
LINE IN		—	—	—	—	—	—	—
LEAD		Note	Velocity	Gate time	—	—	—	—
BASS		Note	Velocity	Gate time	—	—	—	—
RHYTHM (TR recording only)		Rhythm tone	Volocity	—	—	—	—	---
EFFECT		—	—	*	—	—	—	—
LOOP CTRL	Pitch	—	—	Pitch	—	—	—	—
	Trigger	—	—	Part	—	—	—	—
	Divide times 16	—	—	Position	—	—	—	—

* The settings that can be modified will depend on the selected effect type. Refer to “Changing the effect type” (p. 44).

Others

	C1 knob	C2 knob	C3 knob	CUTOFF knob	RESO knob	DECAY knob	[INC]/[DEC]
Loop edit	Pitch	Position	Length	—	—	—	—
Loop pan	—	—	—	—	—	—	Pan

Parameter list

DSP synthesizer parameters

Common to LEAD and BASS

Parameter	Range	Controller	Parameter function
LFO rate	0–120, note value	[SHIFT] + STEP [1]	Specifies the LFO speed. If a note value is selected, the LFO will synchronize to the tempo.
LFO waveform	TRI, SQR, SAW, S-H	[SHIFT] + STEP [2]	Selects the LFO waveform
OSC waveform	TRI, SAW, P10–P30, P1S–P3S, P1D–P3D	[SHIFT] + STEP [3]	Selects the oscillator waveform *1
OSC vibrato depth	0–127	[SHIFT] + STEP [4]	Specifies the depth of vibrato
Filter type	LP1, BP1, HP1, LP2, BP2, HP2	[SHIFT] + STEP [5]	Selects the type of filter (Low Pass Filter, Band Pass Filter, High Pass Filter) * LP1: slope = -12 dB, LP2: slope = -24 dB
Filter envelope attack time	0–127	[SHIFT] + STEP [6]	Specifies the time from when the keyboard pad is pressed until the maximum filter change is reached
Filter envelope sustain level	0–127	[SHIFT] + STEP [7]	Specifies the cutoff frequency at which the filter stops changing
Filter envelope release time	0–127	[SHIFT] + STEP [8]	Specifies the time from when the keyboard pad is released until the filter stops changing
Filter LFO depth	0–127	[SHIFT] + STEP [9]	Applies a wah effect
Amp envelope depth	0–127	[SHIFT] + STEP [10]	Adjusts the depth of the amp envelope
Amp envelope attack time	0–127	[SHIFT] + STEP [11]	Specifies the time from when the keyboard pad is pressed until the maximum volume is reached
Amp envelope decay time	0–127	[SHIFT] + STEP [12]	Specifies the time from when the maximum volume is reached until the sustain level is reached
Amp envelope sustain level	0–127	[SHIFT] + STEP [13]	Specifies the level at which the volume stops changing
Amp envelope release time	0–127	[SHIFT] + STEP [14]	Specifies the time from when the keyboard pad is released until the sound disappears
Amp LFO depth	0–127	[SHIFT] + STEP [15]	Applies tremolo
Effect type (when LEAD is selected)	OD1-2 (overdrive 1-2), DS1-2 (distortion 1-2), PH1-4 (phaser 1-4), SL1-2 (slicer 1-2), OFF (no effect)	[SHIFT] + STEP [16]	Specifies the type of effect
Vintage mode (when BASS is selected)	OFF, ON		Specifies whether the filter characteristics and parameter ranges of a vintage synthesizer will be simulated

*1: For some tones, it is not possible to change the OSC waveform.

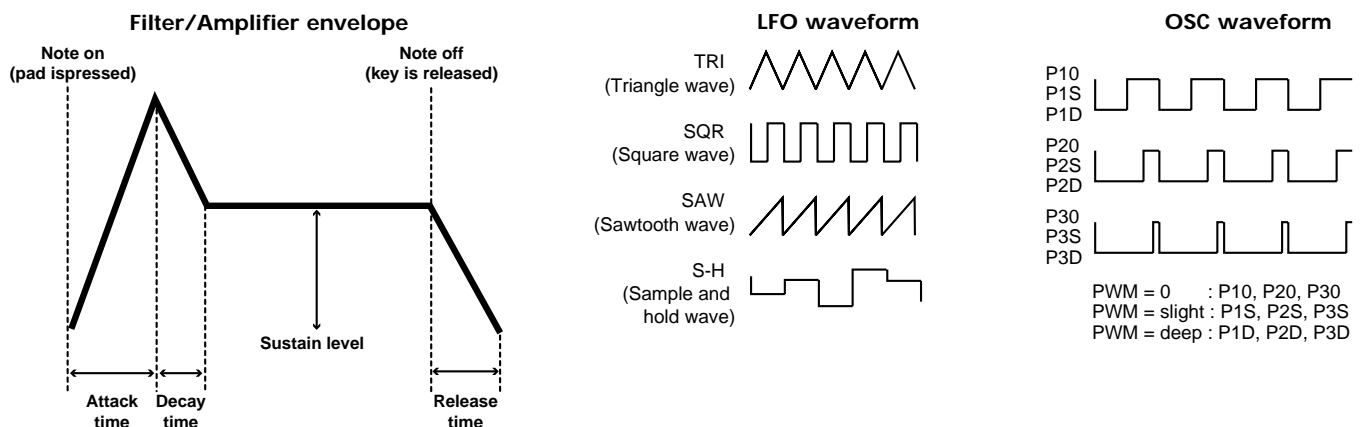

LEAD

	Parameter	Range	Controller	Parameter function
Overdrive/ Distortion	OSC tune	-1-1 (oct)	C1 knob	Adjusts the pitch of the oscillator
	Drive	0-127	C2 knob	Specifies the degree of distortion
	Tone	-64-63	C3 knob	Adjusts the brightness of the sound
Phaser	Rate	0-127 (PH1/3), note value* (PH2/4)	C1 knob	Specifies the speed of modulation (PH1/3). Specifies the modulation speed as a note value (PH2/4).
	Depth	0-127	C2 knob	Specifies the depth of modulation
	Resonance	0-127	C3 knob	Adds character to the sound
Slicer+Ring Modulator	Rate	0-127 (SL1), note value* (SL2)	C1 knob	Specifies the cutting speed (SL1). Specifies the cutting speed as a note value (SL2)
	Gate time	0-127	C2 knob	Specifies the note length that will be cut
	Ring frequency	0-127	C3 knob	Adjusts the frequency of the internal oscillator
Common	Cutoff frequency	0-127	CUTOFF knob	Specifies the frequency (cutoff frequency) at which the filter will begin to take effect
	Resonance	0-127	RESO knob	Emphasizes the region near the cutoff frequency
	Filter envelope decay time	0-127	DECAY knob	Decay time over which the cutoff frequency changes from the maximum value to a stable level
	Tone	Refer to "Sound List" (p. 76)	[INC]/[DEC] buttons (DISPLAY = TONE/ TYPE)	Selects a tone

BASS

Parameter	Range	Controller	Parameter function
OSC tune	-64-63	C1 knob	Adjusts the pitch of the oscillator * When vintage mode is on, the range of this value will change
Filter envelope depth	0-127	C2 knob	Specifies the depth of the filter envelope
Accent	0-127	C3 knob	Emphasizes the sound
Cutoff frequency	0-127	CUTOFF knob	Specifies the frequency (cutoff frequency) at which the filter will begin to take effect
Resonance	0-127	RESO knob	Emphasizes the region near the cutoff frequency
Filter envelope decay time	0-127	DECAY knob	The decay time over which the cutoff frequency changes from the maximum value to a stable level
Tone	Refer to "Sound List" (p. 76)	[INC]/[DEC] buttons (DISPLAY = TONE/ TYPE)	Selects a tone

RHYTHM

Parameter	Range	Controller	Parameter function
Bass drum level	0-127	CUTOFF knob	Specifies the volume of the bass drum
Snare drum level	0-127	RESO knob	Specifies the volume of the snare drum
Hi-hat level	0-127	DECAY knob	Specifies the volume of the hi-hat
Rhythm set	Refer to "Sound List" (p. 76)	[INC]/[DEC] buttons (DISPLAY = TONE/ TYPE)	Selects a rhythm set

* Note value: 16th note, 8th note, quarter note, half note, whole note, whole note x 2, whole note x 4

Parameter list

EFFECTS

Filter

Modifies the brightness of the sound.

Parameter	Range	Controller	Parameter function
Rate	0-127, note value*	C1 knob	Specifies the speed of modulation. If set to a note value, the modulation speed will synchronize to the tempo.
Cutoff frequency	0-127	C2 knob	Specifies the frequency (cutoff frequency) at which the filter will begin to take effect
Resonance	0-127	C3 knob	Emphasizes the region near the cutoff frequency
Effect type	F-1-F-8	[INC]/[DEC] (DISPLAY = TONE/TYPE)	Selects the effect type

Isolator

This is an equalizer that drastically cuts the sound, producing a unique effect by cutting the volume of a specific frequency range.

Parameter	Range	Controller	Parameter function
Low gain	0-127	C1 knob	Specifies the volume of the lower range
Middle gain	0-127	C2 knob	Specifies the volume of the midrange
High gain	0-127	C3 knob	Specifies the volume of the upper range
Effect type	I-1-I-7	[INC]/[DEC] (DISPLAY = TONE/TYPE)	Selects the effect type

Phaser

Adds a phase-shifted sound to the original sound, creating modulation and producing a sense of rotation and depth.

Parameter	Range	Controller	Parameter function
Rate	0-127, note value*	C1 knob	Specifies the speed of modulation. If a note value is specified, the modulation speed will synchronize to the tempo.
Depth	0-127	C2 knob	Specifies the depth of modulation
Resonance	0-127	C3 knob	Emphasizes the region near the center frequency
Effect type	P-1-P-8	[INC]/[DEC] (DISPLAY = TONE/TYPE)	Selects the effect type

Slicer

Repeatedly cuts the sound, giving a conventional sound the character of a rhythmic backing phrase

Parameter	Range	Controller	Parameter function
Rate	0-127, note value*	C1 knob	Specifies the cutting speed. If this is set to a note value, the cutting speed will synchronize to the tempo.
Gate time	0-127	C2 knob	Specifies the note length to cut
Pan	L64-cnt-R63	C3 knob	Specifies the panning of the sound that is cut
Effect type	S-1-S-7	[INC]/[DEC] (DISPLAY = TONE/TYPE)	Selects the effect type

* Note value: 16th note, 8th note, quarter note, half note, whole note, whole note x 2, whole note x 4

System parameters

Operation

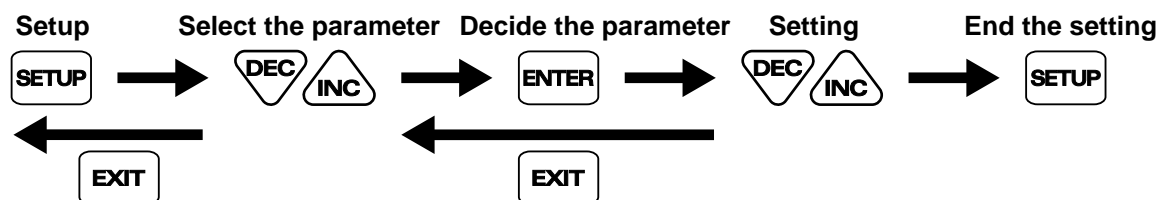

Parameter	Display	Range	Parameter function
Transpose	<i>trS</i>	-12-12	Transposes
Tuning	<i>tun</i>	427.4-452.6 (Hz)	Adjusts the tuning
Sync mode	<i>SYN</i>	INT, SLAVE, REMOTE	Specifies the tempo reference for synchronization
Sync out	<i>SYO</i>	OFF, ON	Specifies whether synchronization-related MIDI messages will be transmitted
MIDI channel	<i>NCn</i>	1-16, OFF	Specifies the MIDI channel. Set this to OFF if you don't want MIDI messages to be transmitted or received
Device ID	<i>dEP</i>	17-32	Specifies the device ID
Soft thru	<i>thr</i>	OFF, ON	Specifies whether received MIDI messages will be retransmitted from the MIDI OUT connector
Local switch	<i>LcL</i>	OFF, ON	Specifies whether the controller section will transmit MIDI messages to the DSP synthesizer section
Receive program change	<i>r.PC</i>	OFF, ON	Specifies whether program changes will be received
Receive control change	<i>r.CC</i>	OFF, ON	Specifies whether control change messages will be received
Receive pitch bend	<i>r.Pb</i>	OFF, ON	Specifies whether pitch bend messages will be received
Receive system exclusive	<i>r.E=</i>	OFF, ON	Specifies whether system exclusive messages will be received
Transmit program change	<i>t.PC</i>	OFF, ON	Specifies whether program change messages will be transmitted
Bulk dump	<i>dNP</i>	PTN, PRC, ALL	Transmits the currently selected pattern and process patch, or all patterns, process patches, and system settings
Bulk load	<i>rcP</i>	—	Load bulk data
Loop load	<i>LPL</i>	—	Load a loop from a memory card into the audio looper
Loop save	<i>LPS</i>	—	Save a loop to memory card
Loop delete	<i>LPd</i>	—	Delete a loop from memory card
All load	<i>ALL</i>	—	Load all loops and internal settings into the MC-09
All save	<i>ALS</i>	—	Save all loops and internal settings to a memory card
All delete	<i>ALd</i>	—	Delete all loops and internal settings from the memory card
Card format	<i>Fnt</i>	—	Format a memory card for use by the MC-09
Factory reset	<i>Fct</i>	—	Return the MC-09 to the factory-set condition

Troubleshooting

If there is no sound, or if the MC-09 does not operate as you expect, please check the following points first. If this does not resolve the problem, please contact your dealer or a nearby Roland Service Center.

* Roland Corporation assumes no responsibility whatsoever concerning the recovery of any recorded content.

Problem	Cause	Action	Page
Does not operate correctly/Power does not turn on	The included AC adaptor is not being used.	Use the included AC adaptor. If the unit does not operate correctly even when the included AC adaptor is used, check that the rated voltage is being supplied.	---
No sound	The MC-09 or a connected device is not powered-on.	Turn on the power.	13
	The volume of the MC-09 or a connected device has been lowered.	Raise the volume	
	MIDI cables or audio cables are not connected correctly.	Make the correct connections.	12
	The part level of the audio looper has been lowered.	Raise the part level.	35
	The volume was turned down during Capture.	Before you capture, make sure that the LEVEL knob, and CUTOFF knob are not at the minimum position.	33
DSP synthesizer sound is interrupted	The LEAD and BASS groups cannot simultaneously play multiple notes.	The currently-sounding note will stop, and the last-played note will sound in its place (last-note priority); utilize this characteristic in your performance.	18
Effect not applied	An effect cannot be applied while a BASS or RHYTHM group pattern is being used.	Capture the performance of the BASS or RHYTHM group pattern to the audio looper, and then apply the effect.	41
Phaser or slicer rate won't synchronize to the tempo	You have selected an effect type that cannot be synchronized.	Select an effect type that allows synchronization.	44
	If synchronizing to the tempo of an external MIDI device, the correct settings have not been made.	Make the correct MIDI synchronization settings.	64
Pattern does not switch	You didn't press the [ENTER] button.	Press the [ENTER] button to finalize the pattern.	16
Can't use loop control	A loop is not recorded in the audio looper.	<ul style="list-style-type: none"> • Capture a loop. • Load a loop. 	33 59
	Loop Control is turned off.	Turn Loop Control on.	53
Pattern does not play when you press the [▶] button	Sync mode is set to "SLAVE."	Set sync mode to "INT" or "REMOTE."	71
	Loop Control is turned on.	Turn Loop Control off.	53
Effect control does not start when you press the [▶] button	Effect Control has not been specified.	Make Effect Control settings.	46
	You have selected an effect type that does not allow effect control.	Select an effect type that supports effect control.	44
	Loop Control is turned on.	Turn Loop Control off.	53
Pattern does not play back at the correct tempo	If you switch patterns while a pattern is playing, the tempo of the first pattern will be maintained.	Stop pattern playback, then start playback over again.	16
Cannot use effect control or loop control at the correct tempo	When synchronizing to the tempo of an external MIDI device, the correct settings have not been made.	Make the correct MIDI synchronization settings.	64
MIDI messages are not transmitted/received	The MIDI channel is not set correctly.	Set the external MIDI device and the MC-09 to the same MIDI channel.	61
	Certain settings are preventing MIDI transmission/reception from taking place.	Parameters such as Tx.Program Change, Rx.Program Change, and Rx.Control Change should be set to "On."	63

Error messages

If you perform an incorrect operation or if the data could not be processed as you specified, an error message will be displayed. Refer to the explanation for the error message that appears, and take the appropriate action.

Message	Cause	Action
E01	A large number of MIDI messages were received all at once, and processing could not be completed.	Reduce the amount of data that is being transmitted.
E02	There is a problem with the MIDI cable connection.	Check whether the MIDI cable is broken or disconnected.
E03	The checksum value of a received exclusive message is incorrect.	Correct the checksum value.
E04	The format of a received exclusive message is incorrect.	Check the data that is being transmitted, and perform the operation once again. Also check whether a MIDI cable is disconnected or broken.
E05	It is possible that the contents of internal memory have been damaged.	Try performing the Factory Reset operation. If this does not resolve the problem, contact a Roland service center.
E12	The specified file does not exist on the memory card.	Specify the file number of an existing file.
E13	The file has an incorrect data format, or has been damaged.	Specify a file of the correct data format.
E14	There is insufficient space on the memory card.	Delete unneeded files to create free space on the memory card.
E15	The memory card is write-protected.	Remove the write protect label.
E16	The memory card is not inserted.	Insert the memory card correctly.
E17	The memory card is not formatted.	Format the card on the MC-09.
	The MC-09 does not support this memory card.	Use a memory card that the MC-09 supports.
	The memory card is damaged.	Replace it with a correctly-functioning memory card.

MIDI Implementation Chart

Function...	Transmitted	Recognized	Remarks
Basic Channel Default Changed	1-16 1-16 *1	1-16 1-16	
Mode Default Messages Altered	Mode 3 OMNI OFF, POLY *****	Mode 3 Mode 3	
Note Number : True Voice	0-127 *****	0-127 0-127	
Velocity Note On Note Off	O X	O X	
After Touch Key's Channel's	X X	X X	
Pitch Bend	X	O *1	
Control Change	0, 32 O	O	Bank select
	1 X	O *1	Modulation
	7 O	O *1	Volume
	10 O	O *1	Panpot
	65 O	O *1	Portament
	16-19 O	X	Step Sequencer
	16 O	O *1	General purpose controller (C1)
	17 O	O *1	General purpose controller (C2)
	18 O	O *1	General purpose controller (C3)
	74 O	O *1	General purpose controller (CUTOFF)
71 O	O *1	General purpose controller (RESO)	
83 O	O *1	General purpose controller (DECAY)	
Program Change : True Number	O *****	O 0-127 *1	Program No. 1-128
System Exclusive	O	O *1	
System Common : Song Position : Song Select : Tune Request	X X X	X X X	
System Real Time : Clock : Commands	O O	O *1 *2 O *1 *3	
Aux Messages : All Sound Off : Reset All Controllers : Local On/Off : All Notes Off : Active Sensing : System Reset	X X X X O X	X O X O (123-127) *4 O X	
Notes	* 1 O X is selectable. * 2 When Sync Mode is SLAVE. * 3 When Sync Mode is SLAVE or REMOTE. * 4 Mode messages (123-127) are stored/transmitted after All Note Off processing is performed.		

Mode 1 : OMNI ON, POLY
Mode 3 : OMNI OFF, POLY

Mode 2 : OMNI ON, MONO
Mode 4 : OMNI OFF, MONO

O : Yes
X : No

* A separate publication titled "MIDI Implementation" is also available. It provides complete details concerning the way MIDI has been implemented on this unit. If you should require this publication (such as when you intend to carry out byte-level programming), please contact the nearest Roland Service Center or authorized Roland distributor.

Specifications

MC-09: Phrase Lab

DSP Synthesizer

● Number of Parts

1

● Maximum Polyphony

LEAD, BASS: 1

RHYTHM: 3

● Preset Tones

LEAD: 128

BASS: 128

RHYTHM: 10

● Effects

Type

FILTER, ISOLATOR, PHASER, SLICER

Number of Types

30

LEAD Group

OVERDRIVE, DISTORTION, PHASER, SLICER + RING
MODULATOR

Step Sequencer

● Number of Steps

32 (Maximum)

● Resolution

sixteenth note

● Tempo

quarter note = 40 to 240

● Preset Patterns

LEAD: 40

BASS: 60

RHYTHM: 100

EFFECT: 30

● User Patterns

LEAD, BASS, RHYTHM, EFFECT: Total 20

External Memory (Memory card)

Pattern, Loop, All: 50 each

Signal Processing

AD Conversion: 24 bits

DA Conversion: 24 bits

Sample Rate

44.1 kHz

Nominal Input Level

INPUT: -10 dBu

Input Impedance

INPUT: 42 k Ω

Nominal Output Level

OUTPUT: -10 dBu

Output Impedance

OUTPUT: 600 Ω

PHONES: 100 Ω

Residual Noise Level

(LINE IN: OFF, input terminated with 150 Ω , IHF-A, typ.)
-88 dBu

Connectors

INPUT L/R Jacks: RCA phono type

OUTPUT L/R Jacks: RCA phono type

Headphones Jack: Stereo miniature phone type

MIDI IN/OUT Connectors

DC IN Jack

Ground Terminal

Memory Card Slot

Power Supply

AC Adaptor (DC 9V)

Current Draw

350 mA

Dimensions

318.6 (W) x 207.2 (D) x 69.5 (H) mm

12-9/16 (W) x 8-3/16 (D) x 2-3/4 (H) inches

Weight

1.2 kg / 2 lbs 11 oz (excluding AC Adaptor)

Accessories

Owner's Manual

AC Adaptor

• ACI-120C

• ACI-230C

• PSB-1U

LEAD CTRL MAP Seal

Phrase CD (CD-EXTRA format)

Memory Card Protector

Options

MIDI Implementation

* 0 dBu = 0.775 V rms

* In the interest of product improvement, the specifications and/or appearance of this unit are subject to change without prior notice.

Sound List

Preset Pattern (LEAD Group)

No.	Pattern Name	T	L	S	T No.	Effect	L Ctrl
P01	Acid Techno 1	140	1	16	16	Distortion 1	-
P02	Hard Trance 1	140	1	16	62	Distortion 1	-
P03	Acid Techno 2	140	2	16	65	Distortion 1	-
P04	Acid Techno 3	140	1	16	94	Distortion 1	-
P05	Hard Trance 2	140	1	16	61	Distortion 1	-
P06	Techno Alarm 1	140	1	16	31	Phaser 1	-
P07	Acid Techno 4	140	1	16	70	Distortion 1	-
P08	Acid Techno 5	140	2	16	14	Distortion 1	-
P09	TB Trance 1	140	1	16	1	Distortion 1	-
P10	BreakBeats 1	140	1	16	16	Distortion 1	-
P11	Trance 1	140	2	16	107	Distortion 1	-
P12	Trance 2	140	2	16	70	Distortion 1	-
P13	Acid Techno 6	140	1	16	81	Distortion 1	-
P14	Acid Techno 7	140	2	16	91	Distortion 1	-
P15	Acid Techno 8	140	2	16	62	Distortion 1	-
P16	Acid Techno 9	140	2	16	65	Distortion 1	-
P17	BreakBeats 2	140	1	16	3	Distortion 2	-
P18	BreakBeats 3	140	1	16	4	Distortion 1	-
P19	Trance 3	140	1	16	75	Phaser 1	-
P20	Trance 4	140	1	16	74	Phaser 1	-
P21	Trance 5	140	1	16	82	Distortion 1	-
P22	Trance 6	140	1	16	69	Distortion 1	-
P23	Trance 7	140	1	16	74	Phaser 1	-
P24	Trance 8	140	1	16	75	Phaser 1	-
P25	Trance 9	140	2	16	4	Distortion 1	-
P26	Trance 10	140	1	16	24	Distortion 1	-
P27	Trance 11	140	1	16	75	Phaser 1	-
P28	TB Trance 2	140	1	16	2	Distortion 1	-
P29	Trance 12	140	1	16	74	Phaser 1	-
P30	Trance 13	140	1	16	20	Distortion 1	-
P31	Techno Seq 1	140	1	16	1	Overdrive 1	-
P32	Techno Seq 2	140	1	16	72	Phaser 1	-
P33	Techno Seq 3	140	2	16	1	Overdrive 1	-
P34	Techno Alarm 2	140	1	16	44	Overdrive 1	-
P35	Techno Pulse 1	140	1	16	29	Distortion 1	-
P36	Techno Pulse 2	140	1	16	80	Slicer 1	-
P37	Techno Pulse 3	140	1	16	1	Slicer 2	-
P38	Techno Noise Seq	140	2	16	58	Distortion 1	Pitch
P39	SE Pulsar	140	2	16	32	Distortion 1	Trigger
P40	SE Blizzard	140	1	16	77	Phaser 1	Divide

No.: Pattern Number
 T: Tempo
 L: Pattern Length
 S: Scale
 T No.: Tone Number
 L Ctrl: Loop Control Type
 Vintage: Vintage Mode

Preset Pattern (BASS Group)

No.	Pattern Name	T	L	S	T No.	Effect	L Ctrl
P01	TB Techno 1	140	1	16	1	On	-
P02	TB Trance 1	140	1	16	1	On	-
P03	Techno 1	140	1	16	66	Off	-
P04	TB Techno 2	140	1	16	6	Off	-
P05	TB Techno 3	140	1	16	1	On	-
P06	Trance 1	140	1	16	11	Off	-
P07	TB BreakBeats	140	1	16	1	On	-
P08	TB Acid Techno 1	140	1	16	107	Off	-
P09	Techno Seq	140	2	16	84	Off	-
P10	House 1	130	2	16	1	Off	-
P11	TB Acid Techno 2	140	1	16	1	Off	-
P12	TB Acid Techno 3	140	1	16	107	Off	-
P13	TB Acid Techno 4	140	1	16	1	On	-
P14	TB Acid Techno 5	140	2	16	16	Off	-
P15	TB Acid Techno 6	140	1	16	1	On	-
P16	TB Acid Techno 7	140	1	16	1	Off	-
P17	TB Acid Techno 8	140	1	16	107	Off	-
P18	TB Acid Techno 9	140	1	16	107	Off	-
P19	TB Acid Techno 10	140	1	16	1	On	-
P20	Trance 2	140	1	16	66	Off	-
P21	Trance 3	140	1	16	66	Off	-
P22	Trance 4	140	1	16	1	Off	-
P23	TB Trance 2	140	2	16	1	Off	-
P24	Trance 5	140	1	16	1	Off	-
P25	Trance 6	140	1	16	3	Off	-
P26	TB Trance 3	140	1	16	1	Off	-
P27	Trance 7	140	1	16	3	Off	-
P28	Trance 8	140	1	16	94	Off	-
P29	TB Techno 4	140	1	16	1	Off	-
P30	TB Techno 5	140	1	16	1	Off	-
P31	TB Techno 6	140	1	16	1	On	-
P32	TB Techno 7	140	1	16	1	Off	-
P33	TB Techno 8	140	1	16	1	Off	-
P34	Techno 2	140	2	16	1	Off	-
P35	TB Techno 9	140	1	16	1	On	-
P36	Techno 3	140	1	16	1	Off	-
P37	TB Techno 10	140	1	16	1	On	-
P38	Techno 4	140	1	16	66	Off	-
P39	TB Techno 11	140	1	16	11	On	-
P40	Techno 5	140	2	16	68	Off	-
P41	House 2	130	2	16	1	Off	-
P42	House 3	130	1	16	1	On	-
P43	House 4	130	2	16	1	Off	-
P44	BreakBeats 1	140	2	16	71	Off	-
P45	BreakBeats 2	140	1	16	3	Off	-
P46	BreakBeats 3	140	1	16	5	Off	-
P47	BreakBeats 4	140	2	16	1	Off	-
P48	BreakBeats 5	140	1	16	1	Off	-
P49	BreakBeats 6	140	1	16	5	Off	-
P50	BreakBeats 7	140	1	16	3	On	-
P51	DnB/2step 1	160	2	16	1	Off	-
P52	DnB/2step 2	160	2	16	1	Off	-
P53	HipHop/R&B 1	100	2	16	1	Off	-
P54	HipHop/R&B 2	100	2	16	1	Off	-
P55	HipHop/R&B 3	100	2	16	1	Off	-
P56	HipHop/R&B 4	100	2	16	1	Off	-
P57	HipHop/R&B 5	200	2	12	1	Off	-
P58	Techno Alarm 1	140	1	16	29	Off	Pitch
P59	Techno Alarm 2	140	1	16	50	Off	Trigger
P60	Techno Sweep	140	1	16	26	Off	Divide

Preset Pattern (RHYTHM Group)

No.	Pattern Name	T	L	S	R No.	L Ctrl
P01	Techno 1	140	2	16	7	-
P02	Hard House	140	1	16	6	-
P03	Latin 1	140	2	16	5	-
P04	Techno Perc 1	140	1	16	9	-
P05	Techno 2	140	2	16	7	-
P06	Electro 1	130	2	16	8	-
P07	House Snare 1	130	1	16	2	-
P08	House Snare 2	130	1	16	2	-
P09	House Fill	130	2	16	2	-
P10	Progressive 1	140	2	16	3	-
P11	Techno 3	140	1	16	9	-
P12	Techno 4	140	2	16	7	-
P13	Techno 5	140	1	16	1	-
P14	Techno 6	140	1	16	1	-
P15	Techno 7	140	1	16	7	-
P16	Techno Snare 1	140	1	16	2	-
P17	Techno Snare 2	140	2	16	2	-
P18	Techno Snare 3	140	1	16	2	-
P19	Techno Snare 4	140	1	16	2	-
P20	Techno Snare 5	140	2	16	2	-
P21	Techno Snare 6	140	1	16	3	-
P22	Techno Snare 7	140	2	16	2	-
P23	Techno Fill 1	140	2	16	2	-
P24	Techno Fill 2	140	2	16	1	-
P25	Techno Fill 3	140	1	16	4	-
P26	Techno Fill 4	140	1	16	7	-
P27	Techno Fill 5	140	1	16	1	-
P28	Progressive 2	140	1	16	7	-
P29	Techno Perc 2	140	1	16	9	-
P30	Techno Perc 3	140	1	16	9	-
P31	Techno Perc 4	140	1	16	9	-
P32	Techno Perc 5	140	1	16	9	-
P33	House 1	130	1	16	2	-
P34	House 2	130	1	16	1	-
P35	House 3	130	1	16	2	-
P36	House 4	130	2	16	4	-
P37	Latin 2	130	2	16	5	-
P38	Latin 3	130	2	16	5	-
P39	Latin 4	140	2	16	5	-
P40	Percussion 1	140	1	16	10	-
P41	Percussion 2	140	1	16	10	-
P42	Percussion 3	140	1	16	10	-
P43	Percussion 4	140	2	16	10	-
P44	Percussion 5	140	1	16	10	-
P45	Percussion 6	140	1	16	10	-
P46	Percussion 7	140	1	16	10	-
P47	Percussion 8	140	1	16	10	-
P48	Percussion 9	140	1	16	10	-
P49	Percussion 10	140	1	16	10	-
P50	Percussion 11	140	1	16	10	-
P51	Percussion 12	140	1	16	10	-
P52	Percussion 13	140	1	16	10	-
P53	Percussion 14	140	2	16	1	-
P54	Percussion 15	140	2	16	8	-
P55	BreakBeats 8beat 1	130	2	16	8	-
P56	BreakBeats 8beat 2	130	2	16	3	-
P57	BreakBeats 8beat 3	130	2	16	3	-
P58	BreakBeats 8beat 4	130	2	16	4	-
P59	BreakBeats 8beat 5	130	2	16	4	-
P60	BreakBeats 8beat 6	130	1	16	4	-
P61	BreakBeats 8beat 7	130	1	16	2	-
P62	BreakBeats 8beat 8	130	2	16	1	-

No.	Pattern Name	T	L	S	R No.	L Ctrl
P63	BreakBeats 8beat 9	130	2	16	3	-
P64	BreakBeats 8beat 10	130	2	16	2	-
P65	BreakBeats 8beat 11	130	1	16	2	-
P66	BreakBeats 8beat 12	130	1	16	3	-
P67	BreakBeats 8beat 13	130	1	16	2	-
P68	BreakBeats 16beat 1	130	2	16	4	-
P69	BreakBeats 16beat 2	130	1	16	3	-
P70	BreakBeats 16beat 3	130	2	16	2	-
P71	BreakBeats 16beat 4	130	1	16	8	-
P72	BreakBeats 16beat 5	130	2	16	4	-
P73	BreakBeats 16beat 6	130	1	16	2	-
P74	BreakBeats 16beat 7	130	1	16	1	-
P75	BreakBeats 16beat 8	130	2	16	4	-
P76	BreakBeats 16beat 9	130	1	16	7	-
P77	BreakBeats 16beat 10	130	2	16	4	-
P78	BreakBeats 16beat 11	130	2	16	2	-
P79	BreakBeats 16beat 12	130	2	16	3	-
P80	DnB/2step 1	160	2	16	2	-
P81	DnB/2step 2	160	1	16	2	-
P82	DnB/2step 3	160	2	16	5	-
P83	Electro 2	130	1	16	8	-
P84	Electro 3	130	1	16	8	-
P85	Electro 4	130	1	16	7	-
P86	Electro 5	130	2	16	8	-
P87	Reggae 1	100	1	16	5	-
P88	Reggae 2	100	1	16	1	-
P89	HipHop/R&B 1	100	1	16	2	-
P90	HipHop/R&B 2	100	1	16	2	-
P91	HipHop/R&B 3	100	2	16	5	-
P92	HipHop/R&B 4	100	1	16	2	-
P93	HipHop/R&B 5	100	1	16	4	-
P94	HipHop/R&B 6	100	1	16	5	-
P95	HipHop/R&B 7	100	1	16	5	-
P96	HipHop/R&B 8	200	2	12	1	-
P97	HipHop/R&B 9	200	2	12	1	-
P98	HipHop/R&B 10	100	2	16	5	Pitch
P99	HipHop/R&B 11	100	1	16	5	Trigger
P00	HipHop/R&B 12	140	2	16	4	Divide

No.: Pattern Number
T: Tempo
L: Pattern Length
S: Scale
R No.: Rhythm Set Number
L Ctrl: Loop Control Type

Sound List

Preset Pattern (EFFECTS Group)

No.	Pattern Name	T	L	S	Effect Type
P01	Slicer 1	140	1	16	S-4
P02	Phaser 1	140	1	16	P-8
P03	Filter 1	140	1	16	F-2
P04	Isolator 1	140	1	16	I-3
P05	Isolator 2	140	1	16	I-2
P06	Filter 2	140	1	16	F-2
P07	Phaser 2	140	1	16	P-5
P08	Slicer 2	140	1	16	S-4
P09	Phaser 3	140	1	16	P-4
P10	Phaser 4	140	1	16	P-8
P11	Phaser 5	140	1	16	P-5
P12	Phaser 6	140	1	16	P-2
P13	Phaser 7	140	1	16	P-5
P14	Phaser 8	140	1	16	P-8
P15	Slicer 3	140	1	16	S-7
P16	Slicer 4	140	1	16	S-6
P17	Slicer 5	140	1	16	S-2
P18	Slicer 6	140	1	16	S-2
P19	Slicer 7	140	1	16	S-2
P20	Slicer 8	140	1	16	S-5
P21	Slicer 9	140	1	16	S-7
P22	Isolator 3	140	1	16	I-7
P23	Isolator 4	140	1	16	I-6
P24	Isolator 5	140	1	16	I-2
P25	Isolator 6	140	1	16	I-4
P26	Isolator 7	140	1	16	I-5
P27	Isolator 8	140	1	16	I-4
P28	Filter 3	140	1	16	F-5
P29	Filter 4	140	1	16	F-3
P30	Filter 5	140	1	16	F-5

User Pattern

No.	Pattern Name	Group	T	L	S	T No./ R No.	Vintage/ Effect
P01	Acid Techno 1	LEAD	140	1	16	16	Distortion 1
P02	Hard Trance 1	LEAD	140	1	16	62	Distortion 1
P03	Acid Techno 2	LEAD	140	2	16	65	Distortion 1
P04	Acid Techno 3	LEAD	140	1	16	94	Distortion 1
P05	Hard Trance 2	LEAD	140	1	16	61	Distortion 1
P06	Techno Alarm 1	LEAD	140	1	16	31	Phaser 1
P07	Acid Techno 4	LEAD	140	1	16	70	Distortion 1
P08	Acid Techno 5	LEAD	140	2	16	14	Distortion 1
P09	Techno 1	BASS	140	1	16	66	Off
P10	Trance 1	BASS	140	1	16	11	Off
P11	TB Trance 1	LEAD	140	1	16	1	Distortion 1
P12	TB Techno 2	BASS	140	1	16	6	Off
P13	TB Techno 3	BASS	140	1	16	1	On
P14	BreakBeats 1	LEAD	140	1	16	16	Distortion 1
P15	Trance 1	LEAD	140	2	16	107	Distortion 1
P16	Trance 2	LEAD	140	2	16	70	Distortion 1
P17	Techno 1	RHYTHM	140	2	16	7	-
P18	Hard House	RHYTHM	140	1	16	6	-
P19	Latin 1	RHYTHM	140	2	16	5	-
P20	Techno Perc 1	RHYTHM	140	1	16	9	-

No.: Pattern Number
 T: Tempo
 L: Pattern Length
 S: Scale
 T/R No.: Tone Number / Rhythm Set Number
 L Ctrl: Loop Control Type
 Vintage: Vintage Mode

LEAD/BASS Tone

No.	Tone Name	Cross Mod	Ring Mod	Effect	Vintage Mode
1	SAW 1	-	-	Distortion 1	Off
2	SAW Detune SAW 1	-	-	Distortion 1	Off
3	SAW Detune SAW 2	-	-	Distortion 1	Off
4	SAW Detune SAW 3	-	-	Distortion 1	Off
5	SAW Detune SAW 4	-	-	Distortion 1	Off
6	SAW 2	-	-	Distortion 1	Off
7	SAW Detune SAW 5	-	-	Distortion 1	Off
8	SAW Detune SAW 6	-	-	Distortion 1	Off
9	SAW Detune SAW 7	-	-	Distortion 1	Off
10	SAW Detune SAW 8	-	-	Distortion 1	Off
11	SAW 3	-	-	Distortion 1	Off
12	SAW Detune SAW 9	-	-	Distortion 1	Off
13	SAW Detune SAW 10	-	-	Distortion 1	Off
14	SAW Detune SAW 11	-	-	Distortion 1	Off
15	SAW Detune SAW 12	-	-	Distortion 1	Off
16	SAW Ring	-	○	Distortion 1	Off
17	SAW Detune SAW Ring 1	-	○	Distortion 1	Off
18	SAW Detune SAW Ring 2	-	○	Distortion 1	Off
19	SAW Detune SAW Ring 3	-	○	Distortion 1	Off
20	SAW Detune SAW Ring 4	-	○	Distortion 1	Off
21	TRI Detune PLS 1	-	-	Distortion 1	Off
22	TRI Detune PLS 2	-	-	Distortion 1	Off
23	TRI Detune PLS 3	-	-	Distortion 1	Off
24	TRI XMod 1	○	-	Distortion 1	Off
25	TRI XMod 2	○	-	Distortion 1	Off
26	TRI XMod 3	○	-	Distortion 1	Off
27	TRI XMod 4	○	-	Distortion 1	Off
28	TRI XMod 5	○	-	Distortion 1	Off
29	TRI XMod 6	○	-	Distortion 1	Off
30	TRI XMod 7	○	-	Distortion 1	Off
31	TRI XMod 8	○	-	Distortion 1	Off
32	TRI XMod 9	○	-	Distortion 1	Off
33	SAW Detune PLS 1	-	-	Distortion 1	Off
34	SAW Detune PLS 2	-	-	Distortion 1	Off
35	SAW Detune PLS 3	-	-	Distortion 1	Off
36	SAW XMod 1	○	-	Distortion 1	Off
37	SAW XMod 2	○	-	Distortion 1	Off
38	SAW XMod 3	○	-	Distortion 1	Off
39	SAW XMod 4	○	-	Distortion 1	Off
40	SAW XMod 5	○	-	Distortion 1	Off
41	SAW XMod 6	○	-	Distortion 1	Off
42	SAW XMod 7	○	-	Distortion 1	Off
43	SAW XMod 8	○	-	Distortion 1	Off
44	SAW XMod 9	○	-	Distortion 1	Off
45	PLS Detune PLS 1	-	-	Distortion 1	Off
46	PLS Detune PLS 2	-	-	Distortion 1	Off
47	PLS Detune PLS 3	-	-	Distortion 1	Off
48	PLS XMod 1	○	-	Distortion 1	Off
49	PLS XMod 2	○	-	Distortion 1	Off
50	PLS XMod 3	○	-	Distortion 1	Off
51	PLS XMod 4	○	-	Distortion 1	Off
52	PLS XMod 5	○	-	Distortion 1	Off
53	PLS XMod 6	○	-	Distortion 1	Off
54	SAW XMod 10	○	-	Distortion 1	Off
55	SAW XMod 11	○	-	Distortion 1	Off
56	SAW XMod 12	○	-	Distortion 1	Off
57	Noise 1	-	-	Distortion 1	Off
58	SAW Noise	-	-	Distortion 1	Off
59	SAW Noise XMod 1	○	-	Distortion 1	Off
60	SAW Noise XMod 2	○	-	Distortion 1	Off
61	SAW Detune SAW 13	-	-	Distortion 1	Off

No.	Tone Name	Cross Mod	RingEffect	Vintage Mode
62	SAW Detune SAW 14	-	-	Distortion 1 Off
63	PLS Detune PLS 4	-	-	Distortion 1 Off
64	SAW Detune SAW 15	-	-	Distortion 1 Off
65	SAW Detune SAW 16	-	-	Distortion 1 Off
66	SAW 4	-	-	Distortion 1 On
67	TRI Detune TRI XMod Ring 1	○	○	Distortion 1 Off
68	SAW Detune SAW 17	-	-	Distortion 1 Off
69	SAW 5	-	-	Distortion 1 Off
70	SAW Detune SAW 18	-	-	Distortion 1 Off
71	SAW Detune SAW 19	-	-	Distortion 1 On
72	SAW Detune SAW 20	-	-	Phaser 2 On
73	SAW Detune SAW 21	-	-	Phaser 2 Off
74	SAW Detune SAW 22	-	-	Phaser 2 Off
75	TRI Detune SAW XMod 1	○	-	Phaser 2 Off
76	SAW Detune PLS 4	-	-	Phaser 2 Off
77	Noise 2	-	-	Phaser 2 Off
78	PLS 1	-	-	Phaser 2 Off
79	SAW 6	-	-	Slicer 2 On
80	TRI Detune TRI XMod Ring 2	○	○	Slicer 2 Off
81	SAW Detune SAW 23	-	-	Overdrive 1 Off
82	SAW Detune SAW 24	-	-	Overdrive 1 Off
83	SAW Detune SAW 25	-	-	Overdrive 1 Off
84	PLS Detune PLS 5	-	-	Overdrive 1 Off
85	SAW Detune SAW 26	-	-	Overdrive 1 Off
86	SAW Detune SAW 27	-	-	Overdrive 1 Off
87	SAW Detune SAW 28	-	-	Overdrive 1 Off
88	SAW 7	-	-	Overdrive 1 Off
89	PLS 2	-	-	Overdrive 1 Off
90	TRI 1	-	-	Overdrive 1 Off
91	PLS Detune SAW 1	-	-	Distortion 1 Off
92	SAW Detune PLS 5	-	-	Distortion 1 Off
93	TRI Detune TRI XMod 1	○	-	Distortion 1 Off
94	SAW Detune SAW 29	-	-	Distortion 1 Off
95	TRI Detune TRI XMod 2	○	-	Distortion 1 Off
96	TRI Detune TRI XMod 3	○	-	Distortion 1 Off
97	PLS Detune PLS XMod 1	○	-	Distortion 1 Off
98	SAW Detune SAW 30	-	-	Distortion 1 Off
99	SAW Detune SAW 31	-	-	Distortion 1 Off
100	SAW Detune TRI XMod Ring	○	○	Distortion 1 Off
101	SAW Detune SAW 32	-	-	Distortion 1 Off
102	SAW 8	-	-	Distortion 1 Off
103	TRI Detune TRI XMod Ring 3	○	○	Distortion 1 Off
104	TRI Detune TRI XMod 4	○	-	Distortion 1 Off
105	PLS Detune PLS XMod Ring	○	○	Distortion 1 Off
106	SAW 9	-	-	Distortion 1 Off
107	SAW Detune SAW 33	-	-	Distortion 1 Off
108	TRI XMod 10	○	-	Distortion 1 Off
109	TRI Detune SAW XMod 2	○	-	Distortion 1 On
110	SAW Detune TRI	-	-	Distortion 1 Off
111	SAW Detune SAW 34	-	-	Distortion 1 Off
112	PLS Detune PLS XMod 2	○	-	Distortion 1 Off
113	TRI Detune PLS XMod Ring	○	○	Distortion 1 Off
114	SAW Detune PLS 6	-	-	Distortion 1 Off
115	SAW Detune SAW 35	-	-	Distortion 1 Off
116	SAW Detune SAW 36	-	-	Distortion 1 Off
117	SAW Detune SAW 37	-	-	Distortion 1 Off
118	Noise 3	-	-	Distortion 1 Off
119	PLS 3	-	-	Distortion 1 Off
120	TRI 2	-	-	Distortion 1 Off
121	PLS Detune SAW 2	-	-	Phaser 2 Off
122	SAW Detune PLS 7	-	-	Phaser 2 Off
123	TRI Detune TRI XMod 5	○	-	Phaser 2 Off
124	SAW Detune SAW 38	-	-	Phaser 2 Off

No.	Tone Name	Cross Mod	RingEffect	Vintage Mode
125	TRI Detune TRI XMod 6	○	-	Phaser 2 Off
126	TRI Detune TRI XMod 7	○	-	Phaser 2 Off
127	PLS Detune PLS XMod 3	○	-	Phaser 2 Off
128	SAW Detune SAW 39	-	-	Phaser 2 Off

RHYTHM Set

NO. Rhythm set Name

1	808 Kit
2	Clap Kit
3	Funk Kit
4	Standard Kit
5	Rim Shot Kit
6	BreakBeats Kit
7	909 Synth Kit
8	Electro Kit
9	Cowbell Kit
10	Latin Perc. Kit

Cross Mod: Cross Modulation
Ring: RIng Modulator

Memo

Index

- A**
 Audio looper 11, 66
- B**
 BPM 57
- C**
 Capture quantize 34
 Capturing 33
- D**
 Divide times 16 50
 DSP synthesizer 11, 66
- E**
 Edit
 Effect 43
 Effect control 46
 Loop control 54
 Pattern 20
 Effect 41
 On/off 42
 Patterns in the LEAD group 17
 Effect control 45
 Play 46
 Effect pattern 42, 48
 Save 48
 Select 42
 Effect routing 41
 Effect type 44
- F**
 Factory reset 5
- G**
 Gate time 26–27, 29
- K**
 Keyboard pads 18
- L**
 Load
 All settings of the MC-09 60
 Loop 59
 Loop 31
 Auditioning a loop 34
 Capturing 33
 Load 59
 Playback 35
 Save 59
 The process of creating a loop 32
 Loop control 49
 Divide times 16 50
 Divide times 16 performace 52
 Edit 54
 Pitch 49
 pitch performance 51
 Trigger 50
 Trigger performace 52
- Loop control pattern
 Play 53
 Save 56
 Loop merge 38
- M**
 Master 61
 Memory card 58
 Delete a saved loop 59
 Delete saved MC-09 settings 60
 Format 58
 Load a loop 59
 Load MC-09 settings 60
 Save a loop 59
 Save all settings of the MC-09 60
 Memory card format 58
 MIDI channel 61
 Mute 36
- O**
 Octave shift 18, 26–27
- P**
 Pan
 Part 36
 Pattern 22
 Part 31
 Erase 39
 Mute 36
 Pattern 14
 BASS group 14
 LEAD group 14
 Play 15
 RHYTHM group 14
 Save 30
 Select 16
 Tempo 17
 Pitch 49
 Playback
 Effect control 46
 Loop 35
 Loop control pattern 53
 Pattern 15
 Process patch 40
 Playback pitch 37
 Preset pattern 14
 Preview 34
 Process patch 39
- R**
 Recording
 Preparations 24
 Step recording 23, 25
 TR recording 23, 27
 Rhythm set 14
 Rhythm tone 14

S

Save

All settings of the MC-09	60
Effect pattern	48
Loop	59
Loop control pattern	56
Pattern	30
Process patch	39
Setup mode	24
Slave	63
Slide-on	26
SmartMedia	58
Standard tempo	31, 57
Step edit	24
Step recording	23, 25
Step sequencer	11, 66

T

Tempo

Standard tempo	31, 57
Tempo of a pattern	17
Tone	14
TR recording	23, 27
Transpose	22
Trigger	50

U

User pattern	14
--------------------	----

V

Velocity	26-29
Volume	
Audio signal	13
DSP synthesizer	13
Overall volume of the MC-09	13
Parts	35

Operation map

Performance

Performance method	Buttons
Play LEAD/BASS/RHYTHM pattern	LEAD / BASS / RHYTHM □ / □ / □
Play LEAD/BASS/RHYTHM pattern (without phrase playback)	SHIFT + LEAD / BASS / RHYTHM □ + □ / □ / □
Play LEAD/BASS/RHYTHM together with an external device	LEAD / BASS / RHYTHM → SHIFT + LINE IN □ / □ / □ → □ + □
Apply effect to loop and/or external device	EFFECTS → SHIFT + SEL → SHIFT + LINE IN □ → □ + □ → □ + □
Input external device	LINE IN □
Play loop using loop control	LOOP CTRL □

Capture

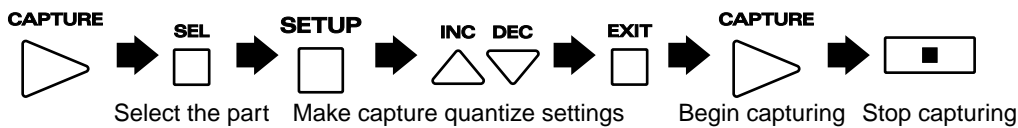

Recording

Getting prepared

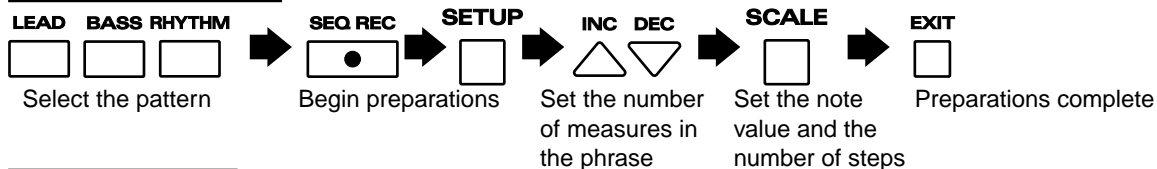

Step recording

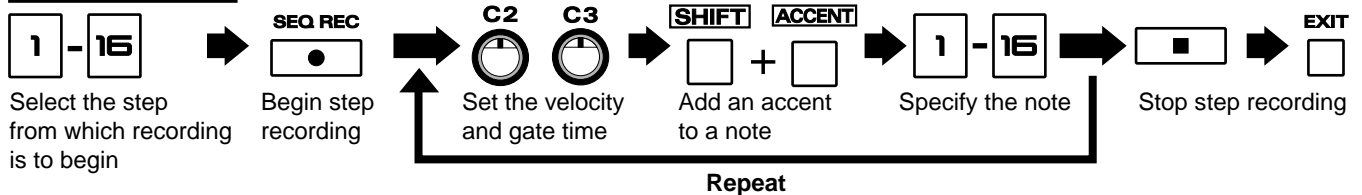

TR recording

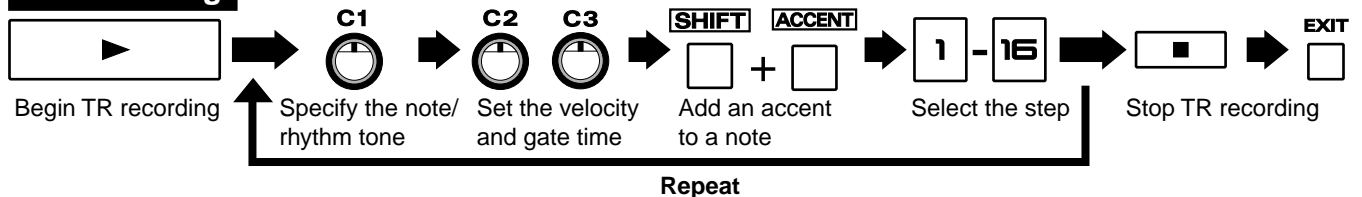

Edit a phrase in pattern

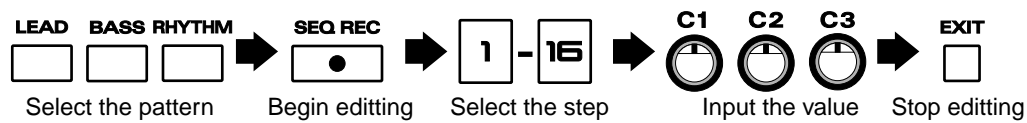

Make effect control settings

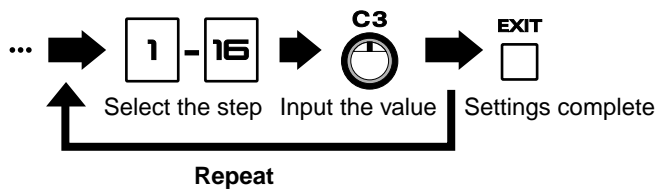
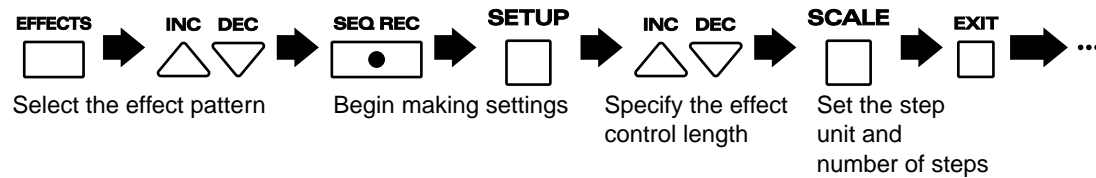

Make loop control settings

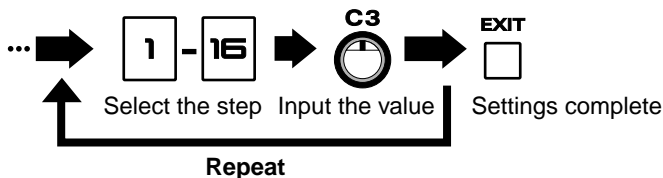
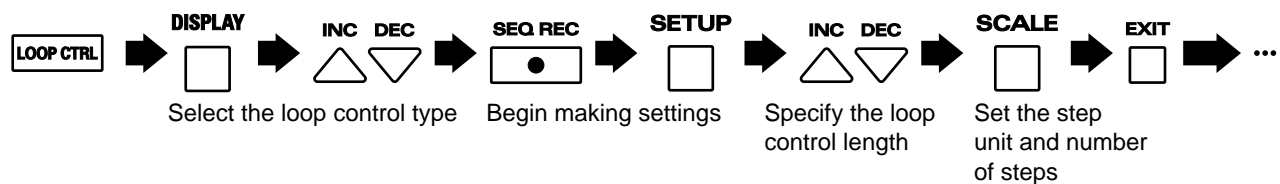

Save the pattern/effect pattern/loop control pattern

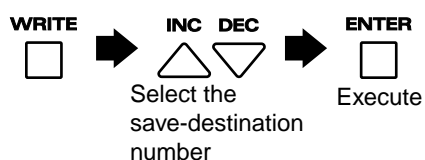

Blank Chart

LEAD

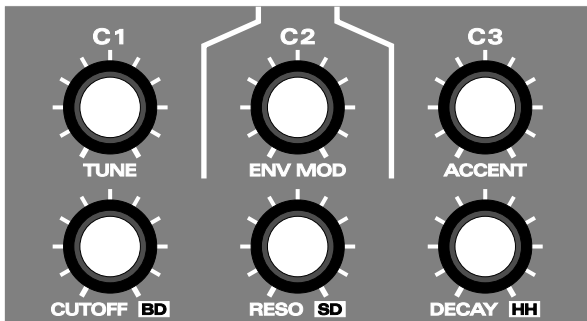
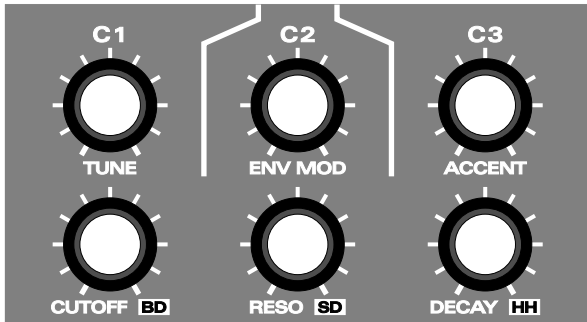

RHYTHM

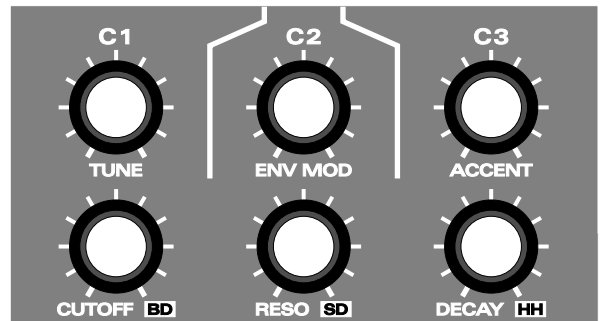
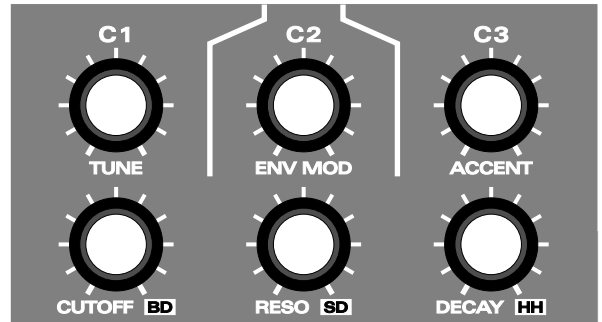

BASS

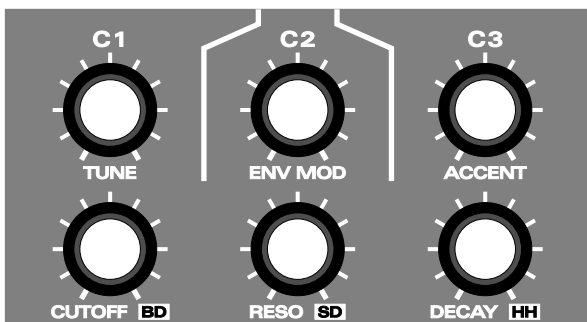
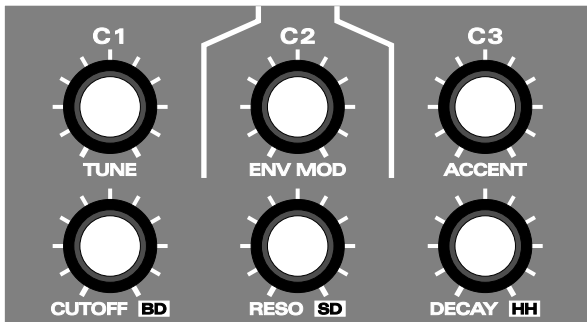

EFFECTS

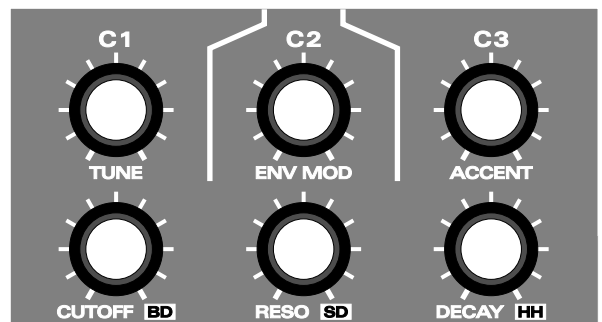
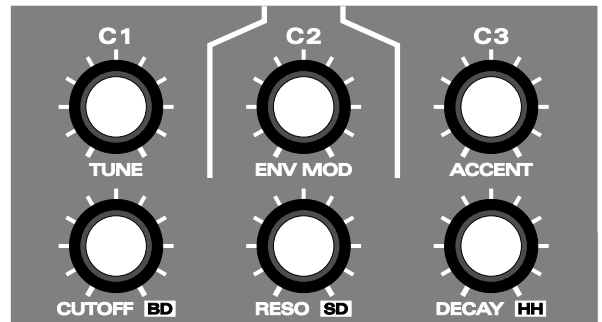

For the U.K.

IMPORTANT: THE WIRES IN THIS MAINS LEAD ARE COLOURED IN ACCORDANCE WITH THE FOLLOWING CODE.

BLUE: NEUTRAL
BROWN: LIVE

As the colours of the wires in the mains lead of this apparatus may not correspond with the coloured markings identifying the terminals in your plug, proceed as follows:

The wire which is coloured BLUE must be connected to the terminal which is marked with the letter N or coloured BLACK.
The wire which is coloured BROWN must be connected to the terminal which is marked with the letter L or coloured RED.
Under no circumstances must either of the above wires be connected to the earth terminal of a three pin plug.

For EU Countries



This product complies with the requirements of European Directive 89/336/EEC.

For the USA

FEDERAL COMMUNICATIONS COMMISSION RADIO FREQUENCY INTERFERENCE STATEMENT

This equipment has been tested and found to comply with the limits for a Class B digital device, pursuant to Part 15 of the FCC Rules. These limits are designed to provide reasonable protection against harmful interference in a residential installation. This equipment generates, uses, and can radiate radio frequency energy and, if not installed and used in accordance with the instructions, may cause harmful interference to radio communications. However, there is no guarantee that interference will not occur in a particular installation. If this equipment does cause harmful interference to radio or television reception, which can be determined by turning the equipment off and on, the user is encouraged to try to correct the interference by one or more of the following measures:

- Reorient or relocate the receiving antenna.
- Increase the separation between the equipment and receiver.
- Connect the equipment into an outlet on a circuit different from that to which the receiver is connected.
- Consult the dealer or an experienced radio/TV technician for help.

This device complies with Part 15 of the FCC Rules. Operation is subject to the following two conditions:

- (1) This device may not cause harmful interference, and
- (2) This device must accept any interference received, including interference that may cause undesired operation.

Unauthorized changes or modification to this system can void the users authority to operate this equipment.
This equipment requires shielded interface cables in order to meet FCC class B Limit.

For Canada

NOTICE

This Class B digital apparatus meets all requirements of the Canadian Interference-Causing Equipment Regulations.

AVIS

Cet appareil numérique de la classe B respecte toutes les exigences du Règlement sur le matériel brouilleur du Canada.

Information

When you need repair service, call your nearest Roland Service Center or authorized Roland distributor in your country as shown below.

AFRICA

EGYPT

Al Fanny Trading Office

9, EBN Hagar A1 Askalany Street,
ARD El Golf, Heliopolis,
Cairo 11341, EGYPT
TEL: 20-2-417-1828

REUNION

Maison FO - YAM Marcel

25 Rue Jules Hermann,
Chaudron - BP79 97 491
Ste Clotilde Cedex,
REUNION ISLAND
TEL: (0262) 218-429

SOUTH AFRICA

That Other Music Shop (PTY) Ltd.

11 Melle St., Braamfontein,
Johannesburg, SOUTH AFRICA

P.O.Box 32918, Braamfontein 2017
Johannesburg, SOUTH AFRICA
TEL: (011) 403 4105

Paul Bothner (PTY) Ltd.

17 Werdmuller Centre,
Main Road, Claremont 7708
SOUTH AFRICA

P.O.Box 23032, Claremont 7735,
SOUTH AFRICA
TEL: (021) 674 4030

ASIA

CHINA

Roland Shanghai Electronics Co., Ltd.

5F, No.1500 Pingliang Road
Shanghai, CHINA
TEL: (021) 5580-0800

Roland Shanghai Electronics Co., Ltd.

(BEIJING OFFICE)

10F, No.18 Anhuaxili
Chaoyang District, Beijing,
CHINA
TEL: (010) 6426-5050

HONG KONG

Tom Lee Music Co., Ltd.

Service Division
22-32 Pun Shan Street, Tsuen
Wan, New Territories,
HONG KONG
TEL: 2415 0911

INDIA

Rivera Digitec (India) Pvt. Ltd.

409, Nirman Kendra Mahalaxmi
Flats Compound Off. Dr. Edwin
Moses Road, Mumbai-400011,
INDIA
TEL: (022) 493 9051

INDONESIA

PT Citra IntiRama

Jl. Cideng Timur No. 15J-150
Jakarta Pusat
INDONESIA
TEL: (021) 6324170

KOREA

Cosmos Corporation

1461-9, Seocho-Dong,
Seocho Ku, Seoul, KOREA
TEL: (02) 3486-8855

MALAYSIA

BENTLEY MUSIC SDN BHD

140 & 142, Jalan Bukit Bintang
55100 Kuala Lumpur, MALAYSIA
TEL: (03) 2144-3333

PHILIPPINES

G.A. Yupangco & Co. Inc.

339 Gil J. Puyat Avenue
Makati, Metro Manila 1200,
PHILIPPINES
TEL: (02) 899 9801

SINGAPORE

Swee Lee Company

150 Sims Drive,
SINGAPORE 387381
TEL: 6846-3676

CRISTOFORI MUSIC PTE LTD

Blk 3014, Bedok Industrial Park E,
#02-2148, SINGAPORE 489980
TEL: 6243-9555

TAIWAN

ROLAND TAIWAN

ENTERPRISE CO., LTD.

Room 5, 9fl. No. 112 Chung Shan
N.Road Sec.2, Taipei, TAIWAN,
R.O.C.

TEL: (02) 2561 3339

THAILAND

Theera Music Co., Ltd.

330 Verng NakornKasem, Soi 2,
Bangkok 10100, THAILAND
TEL: (02) 2248821

VIETNAM

Saigon Music

138 Tran Quang Khai St.,
District 1
Ho Chi Minh City
VIETNAM
TEL: (08) 844-4068

AUSTRALIA/ NEW ZEALAND

AUSTRALIA

Roland Corporation

Australia Pty., Ltd.

38 Campbell Avenue
Dee Why West. NSW 2099
AUSTRALIA
TEL: (02) 9982 8266

NEW ZEALAND

Roland Corporation Ltd.

32 Shaddock Street, Mount Eden,
Auckland, NEW ZEALAND
TEL: (09) 3098 715

CENTRAL/LATIN AMERICA

ARGENTINA

Instrumentos Musicales S.A.

Av.Santa Fe 2055
(1123) Buenos Aires
ARGENTINA
TEL: (011) 4508-2700

BRAZIL

Roland Brasil Ltda

Rua San Jose, 780 Sala B
Parque Industrial San Jose
Cotia - Sao Paulo - SP, BRAZIL
TEL: (011) 4615 5666

COSTA RICA

JUAN Bansbach

Instrumentos Musicales
Ave.1. Calle 11, Apartado 10237,
San Jose, COSTA RICA
TEL: 258-0211

CHILE

Comercial Fancy II S.A.

Rut: 96.919.420-1
Nataliel Cox #739, 4th Floor
Santiago - Centro, CHILE
TEL: (02) 688-9540

EL SALVADOR

OMNI MUSIC

75 Avenida Norte y Final
Alameda Juan Pablo II,
Edificio No.4010 San Salvador,
EL SALVADOR
TEL: 262-0788

MEXICO

Casa Veerkamp, s.a. de c.v.

Av. Toluca No. 323, Col. Olivar
de los Padres 01780 Mexico D.F.
MEXICO
TEL: (55) 5668-6699

PANAMA

SUPRO MUNDIAL, S.A.

Boulevard Andrews, Albrook,
Panama City, REP. DE PANAMA
TEL: 315-0101

PARAGUAY

Distribuidora De

Instrumentos Musicales

J.E. Olear y ESQ. Manduvira
Asuncion PARAGUAY
TEL: (021) 492-124

URUGUAY

Todo Musica S.A.

Francisco Acuna de Figueroa 1771
C.P.: 11.800
Montevideo, URUGUAY
TEL: (02) 924-2335

VENEZUELA

Musicland Digital C.A.

Av. Francisco de Miranda,
Centro Parque de Cristal, Nivel
C2 Local 20 Caracas
VENEZUELA
TEL: (212) 285-8586

EUROPE

AUSTRIA

Roland Austria GES.M.B.H.

Siemensstrasse 4, P.O. Box 74,
A-6063 RUM, AUSTRIA
TEL: (0512) 26 44 260

BELGIUM/HOLLAND/ LUXEMBOURG

Roland Benelux N. V.

Houtstraat 3, B-2260, Oevel
(Westerlo) BELGIUM
TEL: (014) 575811

DENMARK

Roland Scandinavia A/S

Nordhavnsvej 7, Postbox 880,
DK-2100 Copenhagen
DENMARK
TEL: (039) 16 6200

FRANCE

Roland France SA

4, Rue Paul Henri SPAAK,
Parc de l'Esplanade, F 77 462 St.
Thibault, Lagny Cedex FRANCE
TEL: 01 600 73 500

FINLAND

Roland Scandinavia As,

Filial Finland

Lauttasaarentie 54 B
Fin-00201 Helsinki, FINLAND
TEL: (9) 682 4020

GERMANY

Roland Elektronische

Musikinstrumente HmbH.

Oststrasse 96, 22844 Norderstedt,
GERMANY
TEL: (040) 52 60090

GREECE

STOLLAS S.A.

Music Sound Light
155, New National Road
Patras 26442, GREECE
TEL: (061) 043-5400

HUNGARY

Intermusica Ltd.

Warehouse Area 'DEPO' Pf.83
H-2046 Torokbalint, HUNGARY
TEL: (23) 511011

IRELAND

Roland Ireland

Audio House, Belmont Court,
Donnybrook, Dublin 4,
Republic of IRELAND
TEL: (01) 2603501

ITALY

Roland Italy S. p. A.

Viale delle Industrie 8,
20020 Arese, Milano, ITALY
TEL: (02) 937-78300

NORWAY

Roland Scandinavia Avd.

Kontor Norge

Lilleakerveien 2 Postboks 95
Lilleaker N-0216 Oslo
NORWAY
TEL: 273 0074

POLAND

P. P. H. Brzostowicz

UL. Gibraltarska 4.
PL-03664 Warszawa POLAND
TEL: (022) 679 44 19

PORTUGAL

Tecnologias Musica e Audio,

Roland Portugal, S.A.

Cais Das Pedras, 8/9-1 Dto
4050-465 PORTO
PORTUGAL
TEL: (022) 608 00 60

ROMANIA

FBS LINES

Piata Libertatii 1,
RO-4200 Gheorgheni
TEL: (095) 169-5043

RUSSIA

MuTek

3-Bogatyrskaya Str. 1.k.1
107 564 Moscow, RUSSIA
TEL: (095) 169 5043

SPAIN

Roland Electronics

de España, S. A.

Calle Bolivia 239, 08020
Barcelona, SPAIN
TEL: (93) 308 1000

SWEDEN

Roland Scandinavia A/S

SWEDISH SALES OFFICE

Danvik Center 28, 2 tr.
S-131 30 Nacka SWEDEN
TEL: (08) 702 0020

SWITZERLAND

Roland (Switzerland) AG

Musitronic AG

Gerberstrasse 5, Postfach,
CH-4410 Liestal, SWITZERLAND
TEL: (061) 927-8383

UKRAINE

TIC-TAC

Mira Str. 19/108
P.O. Box 180
295400 Munkachevo, UKRAINE
TEL: (03131) 414-40

UNITED KINGDOM

Roland (U.K.) Ltd.

Atlantic Close, Swansea
Enterprise Park, SWANSEA
SA7 9FJ,
UNITED KINGDOM
TEL: (01792) 700139

MIDDLE EAST

BAHRAIN

Moon Stores

No.16, Bab Al Bahrain Avenue,
P.O.Box 247, Manama 304,
State of BAHRAIN
TEL: 211 005

CYPRUS

Radex Sound Equipment Ltd.

17, Diagorou Street, Nicosia,
CYPRUS
TEL: (02) 66-9426

IRAN

MOCO, INC.

No.41 Nike St., Dr.Shariyati Ave.,
Roberoye Cerahe Mirdamad
Tehran, IRAN
TEL: (021) 285-4169

ISRAEL

Halilit P. Greenspoon & Sons Ltd.

8 Retzif Ha'aliya Hashnya St.
Tel-Aviv-Yafo ISRAEL
TEL: (03) 6823666

JORDAN

AMMAN Trading Agency

245 Prince Mohammad St.,
Amman 1118, JORDAN
TEL: (06) 464-1200

KUWAIT

Easa Husain Al-Yousifi

Abdullah Salem Street,
Safat, KUWAIT
TEL: 243-6399

LEBANON

Chahine S.A.L.

Gerge Zeidan St., Chahine Bldg.,
Achrafieh, P.O.Box: 16-5857
Beirut, LEBANON
TEL: (01) 20-1441

QATAR

Al Emadi Co. (Badie Studio

& Stores)

P.O. Box 62,
Doha, QATAR
TEL: 4423-554

SAUDI ARABIA

aDawlah Universal

Electronics APD

Corniche Road, Aldossary Bldg.,
1st Floor, Alkhobar,
SAUDI ARABIA

P.O.Box 2154, Alkhobar 31952
SAUDI ARABIA
TEL: (03) 898 2081

SYRIA

Technical Light & Sound

Center

Khaled Ebn Al Walid St.
Bldg. No. 47, P.O.BOX 13520,
Damascus, SYRIA
TEL: (011) 223-5384

TURKEY

Barkat muzik aletleri ithalat

ve ihracat Ltd Sti

Siraselviler Caddesi Siraselviler
Pasaji No:74/20
Taksim - Istanbul, TURKEY
TEL: (0212) 2499324

U.A.E.

Zak Electronics & Musical

Instruments Co. L.L.C.

Zabeel Road, Al Sherooq Bldg.,
No. 14, Grand Floor, Dubai, U.A.E.
TEL: (04) 3360715

NORTH AMERICA

CANADA

Roland Canada Music Ltd.

(Head Office)

5480 Parkwood Way Richmond
B. C., V6V 2M4 CANADA
TEL: (604) 270 6626

Roland Canada Music Ltd.

(Toronto Office)

170 Admiral Boulevard
Mississauga On L5T 2N6
CANADA
TEL: (905) 362 9707

U. S. A.

Roland Corporation U.S.

5100 S. Eastern Avenue
Los Angeles, CA 90040-2938,
U. S. A.
TEL: (323) 890 3700

As of June 1, 2002 (Roland)